

## 27 HAND AND POWER TOOLS

Employers are responsible for maintaining in good repair any tools and equipment supplied to workers. Workers must use tools and equipment properly and report any defects to supervisors.

The Construction Regulation (O.Reg. 213/91) requires that tools and equipment be used according to manufacturers' operating manuals, that operating manuals for tools and equipment rated at more than 10 horsepower be kept readily available on the project, and that tools and equipment be inspected regularly.

Our finest tools are our **hands**. Too often they are damaged by tool accidents. Hands can be caught in machines, crushed by objects, or cut by sharp-edged tools such as chisels, knives, and saws. Hands can also be damaged by being burned, fractured, or sprained unless you stay alert.

**Eyes** are highly susceptible to injury from tool use but eye injuries are almost always preventable. Use the guards and personal protective equipment which we all know are needed but sometimes tend to overlook.

Noise is a hazard inherent in construction. Tools and the working environment can both be noisy, particularly for construction trades operating in plants and mills. Exposure to excessive noise can impair hearing. Prolonged excessive exposure can result in permanent damage to the hearing and eventually deafness. Hearing protection should be worn whenever there is a risk of excessive exposure.

### Common Causes of Accidents

Typical causes of hand and power tool accidents include the following:

- using the wrong tool for the job
- tools falling from overhead
- sharp tools carried in pockets
- using cheaters on tool handles
- excessive vibration
- using tools with mushroomed heads
- failure to support or clamp work in position
- carrying tools by hand up or down ladders
- using damaged electrical cords or end connectors
- failure to use ground fault circuit interrupters (GFCIs), especially outdoors.

### Safe Practices

Basic hazard awareness and common sense can prevent serious injuries with hand and power tools. As a general rule follow the safe practices listed below.

- 1) **Always wear eye protection.** There is always the risk of flying particles and dust with hand and power tools. Appropriate eye protection is essential and must be worn by the user and others nearby. For eye protection see the Personal Protective Equipment chapter in this manual.
- 2) **Use the right tool for the job.** Using a screwdriver as a chisel, using a cheater on a wrench handle, or using pliers instead of a proper wrench are typical

examples of the mistakes which commonly lead to accidents and injuries.

- 3) **Use tools as recommended by the manufacturer.** For example, don't use cheaters on handles. This will exert greater forces on the tool than it was designed for and is likely to cause breakage and possible injury.
- 4) **Damaged or broken tools should be removed from service.** Chisels with mushroomed heads, hammers with cracked or loose handles, wrenches with worn jaws, damaged extension cords, and ungrounded tools are all unsafe and should be removed from service and be either repaired or destroyed.
- 5) **Maintain tools in safe operating condition.**

**Prevent mushrooming.** Tools which are struck by hammers, such as chisels or punches, should have the head ground periodically to prevent mushrooming. See Figure 21.1

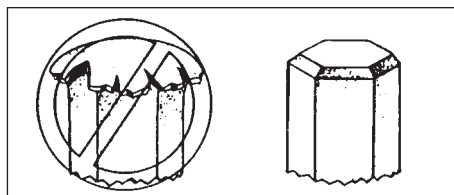

Figure 21.1

**Keep handles secure and safe.** Don't rely on friction tape to secure split handles or to prevent handles from splitting. Check wedges and handles frequently. Be sure heads are wedged tightly on handles. Keep handles smooth and free of rough or jagged surfaces. Replace handles that are split, chipped, or that cannot be refitted securely.

**Keep hand tool cutting edges sharp.** Sharp tools make work easier, improve the accuracy of your work, save time, require less effort, and are safer than dull tools.

- 6) **Never climb ladders with tools in your hand.** Tool holders and pouches (Figure 21.2) free the hands while workers are climbing or working on ladders, scaffolding, and other areas where access may be difficult. When carrying tools up or down from elevated places, put them in substantial bags or boxes and raise and lower them with strong ropes.

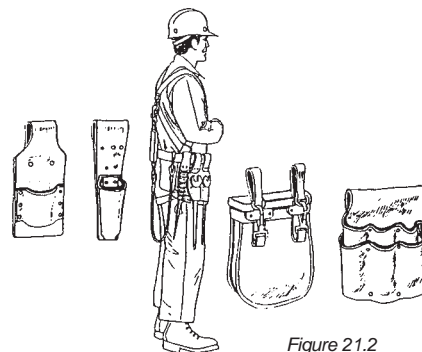

Figure 21.2

- 7) **Spark-resistant tools** (non-ferrous tools) are recommended where flammable materials or explosive dusts or vapours might be present. These tools, such as brass or copper hammers or mallets, should still be used with caution; remember, they may not guarantee safety in all explosive situations such

as in the presence of gasoline vapours. It is always safer to eliminate the hazard by ensuring a safe atmosphere through isolation, ventilation, or purging.

- 8) **Protect the cutting edges of tools when carrying them.** Carry them in such a way that they won't be a hazard to yourself and others. Carry pointed or sharp-edged tools in pouches or holsters.
- 9) **Keep your hand tools clean.** Protect them against damage caused by corrosion. Wipe off accumulated dirt and grease. Dip the tools occasionally in cleaning fluids or solvents and wipe them clean.
- 10) **Lubricate** adjustable and other moving parts to prevent wear and misalignment.
- 11) **When swinging a tool,** be absolutely sure that no one else is within range or can come within range of the swing or be struck by flying material.
- 12) **Falling tools** are a dangerous hazard for workers below. Keep track of tools, especially when working at heights on scaffolds or other access equipment. An unnoticed file or chipping hammer, if accidentally kicked off the work platform, is a deadly missile as well as a tripping hazard for you. **If practical, tie tools off when working at heights.**
- 13) **Hearing protection** should be worn whenever there is a chance of excessive noise exposure. Noise from tools and equipment is an inherent hazard in construction. Exposure to excessive noise can impair hearing. Prolonged excessive exposure can result in permanent damage to hearing and eventually deafness. Although the tools being used are only one of several possible sources of noise, efforts should be made to provide the least noisy power tools that will still do the job.

## Inspection and Repair

Tools should be inspected by a person qualified through training and experience to determine the safe condition of the tool.

Worn or damaged tools should be tagged "**DEFECTIVE – DO NOT USE**" and returned to the shop for repair or replacement.

Regular inspection of all tools is necessary and should cover tool maintenance and service as outlined in the operator's manual. Observing proper handling and storage of tools should also be a part of the inspection process. Responsibility for inspection is usually left to the supervisor. However, tools should be checked by those who use them daily.

Hand tools that get the heaviest use and abuse, such as chisels, hammers, and wrenches, should be inspected frequently and regularly.

To maintain and repair tools properly requires the right facilities and equipment. A good workbench, repair tools, vises, and good lighting are necessities. Only persons skilled in the repair of tools should be allowed to do the repairs. Otherwise tools should be sent out to a qualified repair depot.

## Redressing Tools

Follow the tool manufacturer's recommendations to repair, shape, or maintain tools.

When redressing the cutting edge on a tool, ensure that the tool is supported firmly. Use only a hand file or whetstone—not a grinding wheel. **(If a grinder is used, it can destroy the temper of the cutting edge.)** Be sure to restore the original contour of the cutting edge.

Cold chisels, for example, are hardened on the cutting edge. Use only a hand file or whetstone for redressing. Be sure to restore the cutting edge to its original shape and angle of approximately 70 degrees (Figure 21.3).

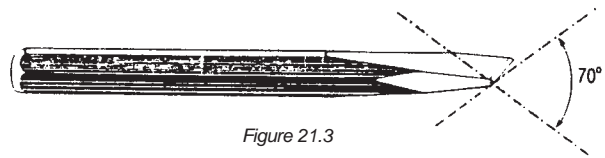

Figure 21.3

## Handles

Hand tools such as hammers and sledgehammers should have handles of straight-grained hickory, ash, or maple and be free from slivers. It is important to ensure that handles are attached and properly fitted to tools by an experienced person. Poorly fitted handles can be very dangerous and make the tool difficult to control.

Constant inspection is necessary for handles. Even though they are received in good condition, handles can loosen with use and shrinkage. In some cases, tapping the wedges may take up the shrinkage. In other cases the head of the tool can be driven back on the handle and the wedges reset and any protruding piece of the handle cut off.

Most wooden handles will need replacement eventually. A replacement handle should be of correct specifications for a tight fit and be properly wedged.

## Safety Tip

Whenever possible, **pull** on an adjustable wrench. Do not push. Force should be exerted on the fixed rather than the adjustable jaw.

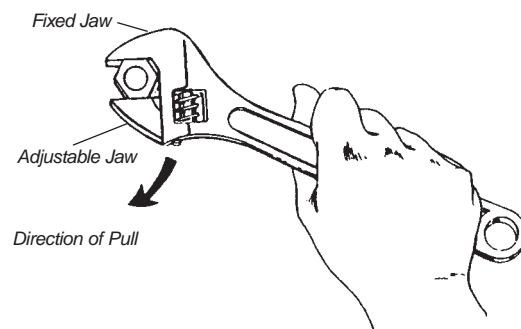

## Hand Tools

### Use

The **misuse** of hand tools is a common cause of injury in construction. In many cases, the injury results because it is assumed that everyone knows how to use most common hand tools. This is not the case.

It is the responsibility of the supervisor and employer to ensure that workers are trained in the safe and proper use of hand tools. This section is intended to provide an overview of hazards and safe practices in selecting and using hand tools.

## Hammers, Sledges, and Mauls

Hammers are made in various shapes and sizes for specific jobs. They should be selected and used only for the purpose intended.

### Ballpeen hammers

These come in a variety of weights up to 3 pounds. Ballpeen hammers are designed for striking cold chisels and punches and for riveting, shaping, and straightening metal (Figure 21.4).

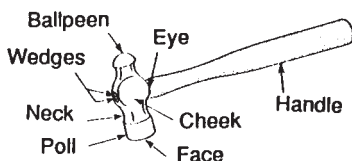

Figure 21.4  
Standard ballpeen hammer

### Sledges

All patterns of this heavy-duty striking tool have a crowned face with bevelled edges. Sledges are forged from high-carbon or alloy steel and are heat-treated. The types most commonly used are:

**Double-face** — head weights from 4 to 20 pounds and handle lengths from 15 to 36 inches. The 8-pound sledge is heavy enough for most boilermakers' work, although heavier sledges may be required for fairing tank seams or for driving wedges on heavy plate work. The 4-pound maul or sledge is a favourite with fitters and is often carried on their belts. With a shorter handle (10 to 12 inches) permitting heavy blows with a limited swing, its weight makes it ideal for driving in full pins for lining up shelf plates (Figure 21.5).

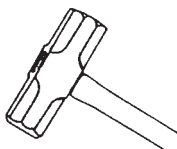

Figure 21.5  
Double or maul-faced sledge

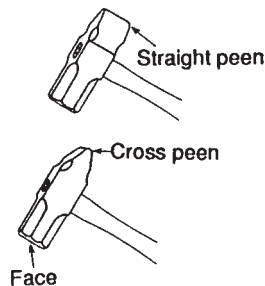

Figure 21.6  
Straight and cross-peen sledges

**Straight or crosspeen sledges** — head weights are from 2 to 16 lbs. and handle lengths from 14 to 36 inches. These peens are used for shaping (fullering) and bending metal (Figure 21.6).

**Chipping hammers** — come in a variety of styles and handles and are designed for chipping slag off welds or burned edges. These hammers have long, slender or tapered points or edges and can be resharpened many times.

**Other types of hammers** — are used when required by the tradesperson. They include carpenter's or claw hammers for nailing; various soft-faced mallets, when a steel head might damage the work; and brass or copper heads, when non-sparking tools are required.

### Basic rules for safe hammer use

- Always wear eye protection.
- Make sure the handle is tight. Never use a hammer with a loose or damaged handle.
- Always strike the work surface squarely with the hammer face. Avoid glancing blows.
- Hold the hammer with wrist straight and hand tightly wrapped around the handle.
- Look behind and above before swinging the hammer.
- Never use a hammer to strike another hammer.
- Discard any hammer with dents, cracks, chips, or mushrooming. Redressing is not recommended.
- When striking another tool (chisel, punch, wedge, etc.), the striking face of the hammer should have a diameter at least 1/2 inch (1 cm. +) larger than the struck face of the tool.
- Never weld or reheat-treat a hammer.

### Struck or Hammered Tools

These include chisels, punches, drift pins, and wedges. General safety measures for their use include:

- 1) Always wear eye protection. If other people are close by, put up a screen or shield to protect them from flying chips.
- 2) Strike the tool squarely and in the centre, as called for by the crow or beveled-face design. Off-centre blows can misdirect the tool and increase the rate of wear on the head.
- 3) Never use a tool with a mushroomed or chipped head. Remove it from service and destroy or repair it.
- 4) Keep cutting edges sharp. A dull edge increases labour and decreases tool durability. Failures can be caused by dullness.

**Cold chisels** have a cutting edge that will cut, shape, or remove metal which is softer than the cutting edge. Such metals include cast iron, wrought iron, mild steel, bronze, and copper. The hardened cutting edge should be kept sharp at a 60- to 70-degree angle. The selection of chisel is determined by the material to be cut and the size and depth of cut. The most commonly used type is the **flat chisel**. It is used to cut rivets, split nuts, chip castings, cut thin plate, remove burn slag and weld spatter, and cut off small rods and wire. Other varieties of cold chisels include: **cape** — for keyways, grooves, square corners; **half round** and **round nose** — for round grooves and to chip inside corners; and **diamond point** — for V-grooves to remove tubes from sheets

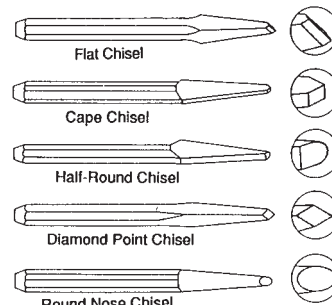

Figure 21.7  
Metal cutting chisel types

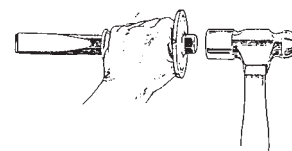

Figure 21.8

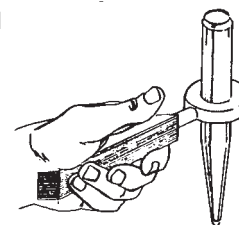

Figure 21.9

and for chipping tack welds and square corners. See Figure 21.7.

A sponge rubber pad forced down over the chisel provides a protective cushion that reduces shock for the hand, but a protective guard such as the one shown in Figure 21.8 is more effective.

**Bull chisels** held by one worker and struck by another require the use of tongs or a chisel holder to guide the chisel so that the user will not be injured (Figure 21.9).

## Punches and Pins

- Select punches or pins heavy enough for the work.
- Avoid jamming tapered parts of punches in openings.
- Avoid bending or breaking pins.
- Make sure pins or punches are held firmly in position before hitting them, especially on rounded surfaces.

**Hand punches** have a variety of configurations for various purposes. When using punches, hold them at right angles to the work surface to prevent side-slipping. Be sure to strike the punch squarely with the hammer to prevent its slipping off and hitting fingers. Figure 21.9a shows some types. In addition, there are blacksmith-type punches (not shown), mounted on hammer style handles; a tapered round point, for drifting and aligning; and a straight punch for backing out bolts, rivets, and pins.

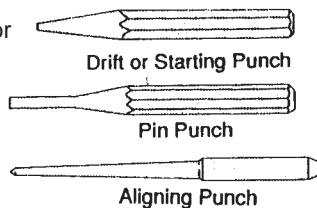

Figure 21.9a  
Types of Punches

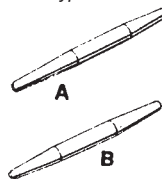

Figure 21.10  
Drift Pins: A Standard; B Barrel

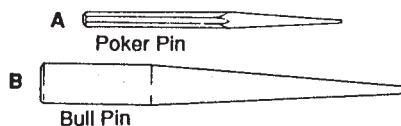

Figure 21.11  
Special Boilermaker Pins  
A: Poker and B: Bull

There are also special pins used largely by boilermakers (Figure 21.11) for heavy-duty steel plate. These include the **poker pin**, a large diameter punch for aligning holes in steel plate; and the **bull pin**, a heavy-duty pin used in the fit-up of steel plate. They are inserted into holes in fit-up clamps (welded temporarily to the side of the plates) to align the plates for welding.

## Cutting Hand tools

### Bolt Cutters

Bolt cutters (Figure 21.12) typically come in lengths of 18" to 36" with the larger ones able to cut mild-steel bolts and rods up to 1/2" diameter, as well other materials such as wire rope. With these tools, observe the following.

- Wear eye protection.
- Keep fingers clear of jaws and hinges.
- Cut ends can fly and cause injury. Try wrapping burlap or a rag around the jaws while cutting.
- Keep jaws at right angles to material. Don't pry or

twist — chips can break off and fly, causing injury or damaging the blade.

### Snips

Snips (Figure 21.13) are generally used to cut light-gauge galvanized sheet metal, copper sheet, and tin. Flying metal particles are always a hazard. Safety glasses or a face shield should be worn to protect against eye injury.

Always be sure to select the right size and type of snips for the job. Don't cut wire with snips — use wire cutters.

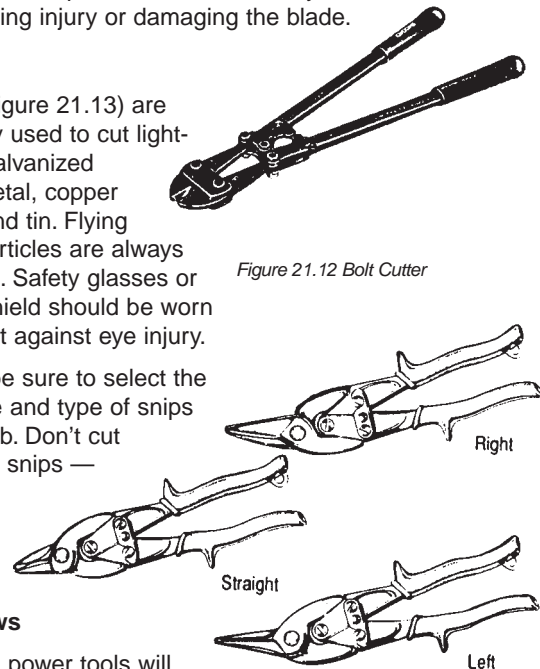

Figure 21.12 Bolt Cutter

Figure 21.13 Snips

### Hacksaws

Although power tools will be used whenever possible, hacksaws deserve mention. They fill a gap by cutting metal too heavy for snips or bolt cutters. The main danger from hacksaws is hand injury due to blade breakage. To prevent this danger:

- install and keep the blade taut but not too tight
- make sure that the material is held firmly in a vise or by other devices such as clamps.

### Files

There are three standard American-pattern metal file cuts as shown in Figure 21.14.

Make sure that a handle is installed on a file before use. This will prevent the chance of an uncovered tang being jammed into your hand. A firmly attached handle will also improve control of the tool.

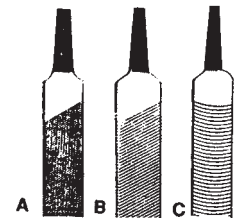

Figure 21.14 Metal file cuts:  
A) single cut, B) double cut,  
C) curved cut

### Taps and Dies

- Keep taps and dies clean and well oiled when not in use.
- Store taps and dies so that they don't contact each other or other tools. For long term storage coat them with rust preventive compound and store in a dry place.
- Don't attempt to sharpen taps or dies. Precise cutting is required to maintain the correct thread-cutting characteristics and chamfer. This work must only be done by experienced personnel.
- Don't use diestocks or tapwrenches as hammers or prybars.

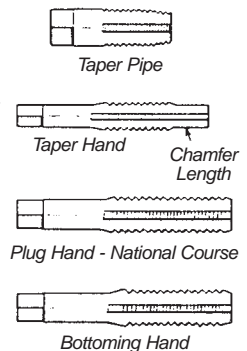

Figure 21.15 Types of common taps.



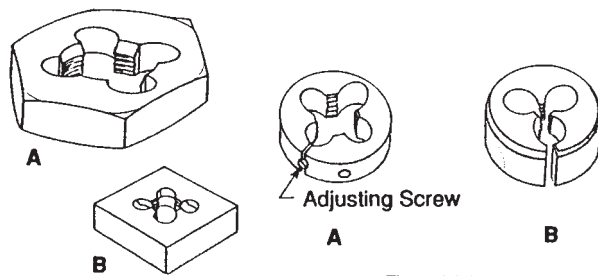

Figure 21.16  
Types of solid dies:  
A) rethreading; B) square pipe

Figure 21.17  
Common adjustable dies:  
A) screw adjusting type;  
B) open adjusting type

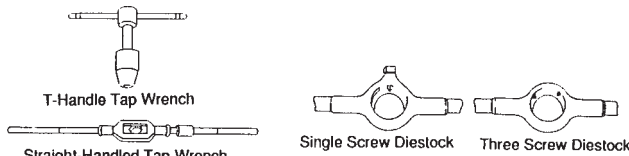
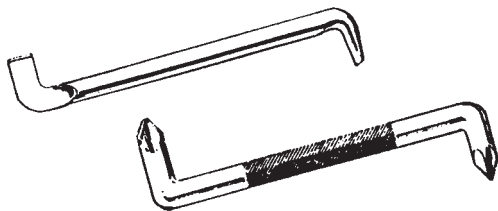

Figure 21.18 Diestock and tap wrenches

## Screwdrivers

This is probably the most abused of all tools. It's used as a punch, wedge, pinch bar, and for other jobs for which it was not designed. Broken handles, bent or chipped blades, and twisted tips may cause the screwdriver to slip and cause a serious hand injury.

- Choose a screwdriver with a rectangular handle that fits the shank tightly, with a flange to keep your hand from slipping off the handle.
- Never get any part of your body in front of the screwdriver. Never hold the work in your hand while using a screwdriver. Hold the work in a vise, with a clamp, or at least on a solid surface.
- Keep screwdriver handles clean. A greasy handle can cause an accident.
- When working around electricity, use screwdrivers with a handle insulated with dielectric material. Keep in mind, however, that this insulation is only a secondary method of protection. Always be sure electrical power is off before beginning work.
- Don't use screwdrivers as chisels, hammers, prybars or for any purpose other than to turn screws.
- Be sure to use the right screwdriver for the screw being turned. The blade must fit the screw type, be in good condition, and seat solidly in the screw slot(s).
- Use an offset screwdriver in close quarters where a conventional screwdriver won't fit.



## Holding Tools

### Wrenches

There are hazards with all types of wrenches: the wrench may slip off the work, the workpiece may suddenly turn free, the wrench or workpiece may break. The user should always be braced to maintain balance and keep from

being injured in case the wrench slips. Always inspect a wrench for flaws, damaged parts, or wear that can cause it to slip and damage fasteners.

There is a correct wrench for every job. If the wrench is too big, it may not grip securely. Overtorquing can cause slippage and damage of the wrench or fastener, including the stripping of threads. Where possible, use penetrating oil to loosen tight nuts and bolts.

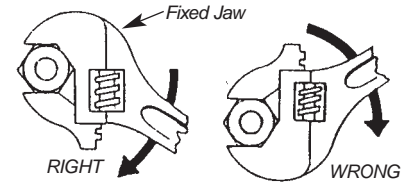

Figure 21.19

- Always grip the wrench so it will not cause injury if it slips.
- Use the correct type of jaw to avoid slippage. Box wrenches are safer than open-end wrenches since they are less likely to slip. Solid open-end wrenches of the correct size are generally more secure than an adjustable wrench, especially on hard-to-turn items.

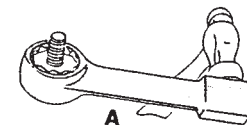
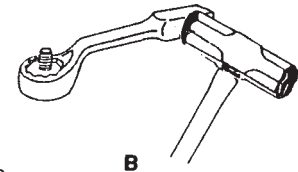

Figure 21.20 Hammer wrenches  
(A) offset hammer wrench  
(B) straight hammer wrench

- Discard any damaged box or open-end wrench. Don't attempt to repair a wrench with rounded or damaged points on the box end or worn or spread jaws on the open end.
- Face the adjustable wrench forward and turn it so pressure is against the fixed jaw (Figure 21.19).
- Always **pull** on a wrench whenever possible. Do not push.
- **Never overload a wrench by using a pipe extension on the handle or by striking the handle with a hammer.** This can weaken the metal of the wrench and cause the tool to break. Heavy-duty box wrenches with extra long handles and "hammer" or striking-face wrenches are available for these jobs. The striking-face wrenches with 12-point box opening are designed for striking with a ballpeen or sledge hammer. Both offset and straight styles are available but the straight type should be used when possible.

**Spud wrenches** are specialized tools with a fixed or box end. The other end is long and tapered, giving extra leverage. It can be used to align holes and pry steel plates. These are also available in an offset (or structural) style for clearing obstructions.

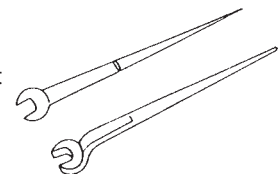

Figure 21.21  
Typical spud wrenches

### Socket Wrenches

Socket wrench sets come in many types and sizes of socket. Drivers include ratchet, universal, and speeder, along with many extensions and adapters. Be careful when adapting down in size not to overtorque a smaller socket and fastener with a larger driver.

Always use the correct size of socket and make sure it fits snugly. An oversize or sloppy fit can cause slippage and injury as well as wear to both the socket and the fastener.

**Never use “hand” sockets on a power drive or impact wrench.** Hand sockets are normally brightly finished while power and impact sockets have a dull finish and usually thicker walls.

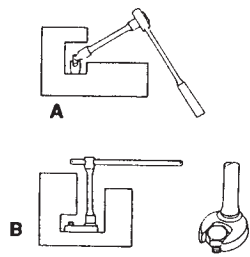
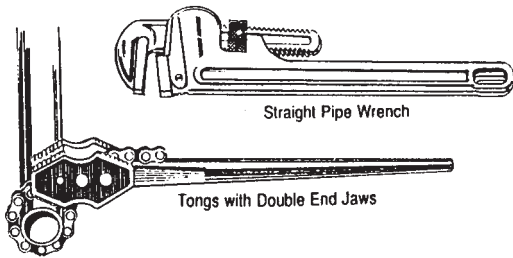

Figure 21.22 Useful socket items:  
A) Universal socket  
B) crowfoot attachment

Two useful socket items are illustrated in Figure 21.22 — a universal joint with an extension and a crowfoot attachment. They allow access into otherwise inaccessible locations.

**Pipe wrenches** have been the cause of serious injuries when used on overhead jobs. Wrenches can slip on pipes or fittings, causing the worker to lose balance and fall. Pipe wrenches, whether straight or chain tong, should have sharp jaws and be kept clean to prevent slipping.



## Pliers

Considered a general purpose tool, pliers are frequently misused. Pliers are meant for gripping and cutting operations and are **not** to be used as a wrench because their jaws are moveable and may slip.

### Basic safety rules

- Choose pliers with enough space between the handles to prevent pinching of the palm or fingers.
- Select pliers that have a grip span of 6 cm to 9 cm (2-1/2"–3-1/2").
- **Pull** on pliers — do not push.
- Side cutting pliers may cause injuries when ends of wire are cut and fragments fly into a worker's eye. Eye protection should be worn when using side cutters.
- Always cut at right angles. Never rock from side to side against the cutting edges.
- Pliers used for electrical work should be insulated. Power must still be shut off first. Remember — cushion grips on handles are for comfort only and are not intended to protect against electrical shock.
- Never expose pliers to excessive heat; this may draw the temper and ruin the tool.

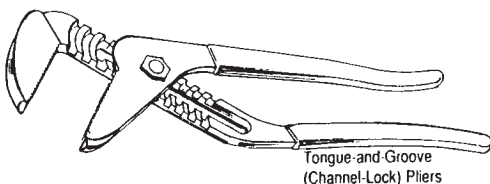

- Don't use pliers as hammers — they might crack, break, or be nicked.
- Don't use cheaters to extend the handles. This can damage or spring the tool, or slip and cause injury.
- Pliers should not be used to tighten nuts or bolts. Use a wrench.

## Locking Wrench Pliers

Sometimes referred to by the trade names vise grips or grip-locks, these can be locked onto a wide variety of objects, leaving the hands free for other work. They are useful as a clamp, a speed wrench, or as a portable vise. Standard types of locking wrench pliers are shown in Figure 21.23 while Figure 21.24 displays speciality styles.

- Don't use them to replace wrenches since they can damage fittings or fasteners.
- Don't hammer or use cheaters to increase force to tighten jaws or to cut wire or bolts.
- Don't expose to heat from torches or contact with welding electrodes.
- Severe vibration can cause release of the jaws accidentally; wire or tape them shut when necessary.
- Never clamp them or attempt to use as a step or climbing device.

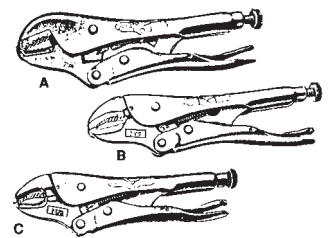

Figure 21.23 Locking wrench pliers with  
A) straight jaws; B) curved jaws; and  
C) curved jaws with wire cutters

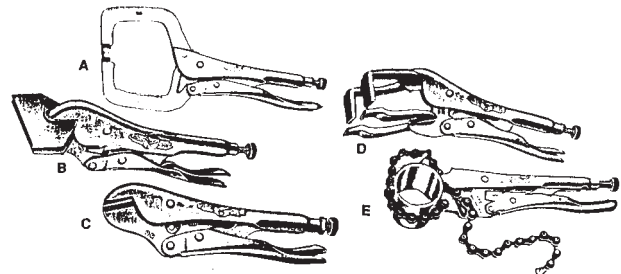

Figure 21.24 Some special locking wrench pliers: A) C-clamp;  
B) sheet metal clamp; C) pinch off tool; D) welding clamp; and E) chain clamp

## Clamps

Clamps are another useful holding tool and the C-clamp (Figure 21.25) is the most widely used style. C-clamps, like other tools, require some maintenance; lubricate periodically, keep threads clean and free of rust, and make sure the swivel head rotates freely.

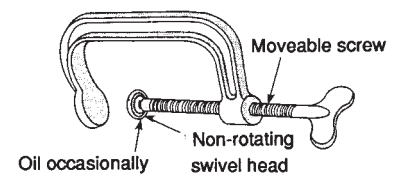

Figure 21.25 Typical C-clamp

For larger clamping jobs there are bar clamps and pipe clamps, which offer a reach limited only by the pipe length used.

The following points should be considered when using clamps.

- Choose a clamp size suited to the job; too small and the clamp can be overloaded and bend or break the body; too large and it can be an obstruction.
- Overextending the screw can bend it.

- Don't use wrenches on the screws unless the clamp is designed for this service, with a bolt head to withstand wrench tightening.
- For welding, use clamps with a shielded thread (Figure 21.26) to prevent damage to the threads from spatter.

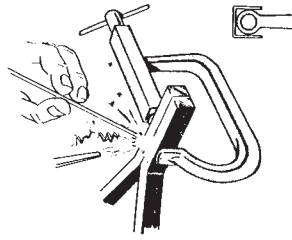
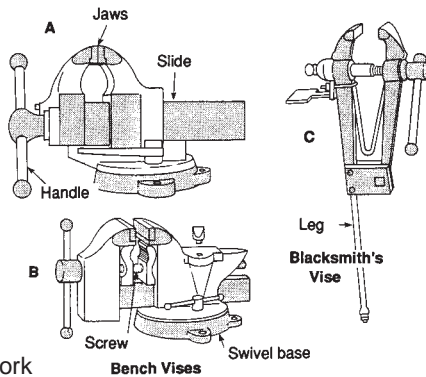

Figure 21.26 Welding C-clamp

**Vises**

The types of vises likely to be used by the various trades are shown in Figure 21.27. The most commonly used is the “bench” vise which can come with a fixed or swivel base. They are also available with or without pipe holding jaws. Bench vises are usually bolt-mounted to a bench but clamp-on models are also available for lighter duty.



The blacksmith's vise is useful for work which must be pounced; it is secured to a bench and braced by the long leg attached to a solid base on the floor.

Pipe vises are also useful to various trades. The yoke-type pipe vise usually has capacity up to about 8 cm. (3 in.).

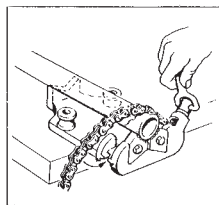

Chain Vise

Figure 21.27

The chain-type vise has a larger diameter capability as well as being useful for irregular shapes.

**Safe use**

- Mount vise securely.
- Keep work close to jaws.
- Keep vise cleaned, oiled.
- Support extra-long work.
- Prop very heavy work in vise with wood blocks to prevent it from falling and causing injury.
- Don't open jaws beyond their capacity; the moveable jaw may fall, causing injury or damage.

**Pipe Tools**

Pipe wrenches have been the cause of serious injuries when used on overhead jobs. Wrenches can slip on pipes or fittings, causing the worker to lose balance and fall. Pipe wrenches, whether straight or chain tong, should have sharp jaws and be kept clean to prevent slipping (Figure 21.28).

- The adjusting nut of the pipe wrench should be inspected frequently for cracks. A cracked nut may break under strain, causing a failure of the wrench and serious injury.
- Use a wrench the right length and size for the job. A wrench that is too small will not provide enough leverage or proper grip. A wrench that is too big is more apt to slip on the work.
- Face the pipe wrench forward. Turn the wrench so that pressure is against the heel jaw.
- Never use a “cheater” to extend the length of a wrench handle and provide more leverage. The cheater may strain the wrench or the work to the breaking point.

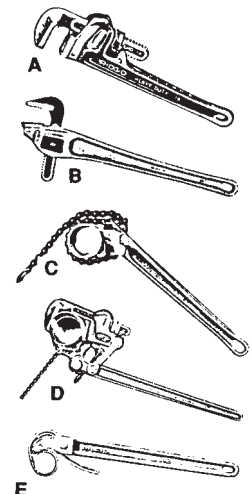

Figure 21.28 typical pipe wrenches: A) Straight, B) Offset, C) Heavy-duty chain wrench, D) Compound leverage wrench, and E) Strap Wrench

**Pipe Visers**

Pipe visers have been discussed briefly; however, another configuration is the portable trisland equipped with either a chain vise or yoke vise (Figure 21.29).

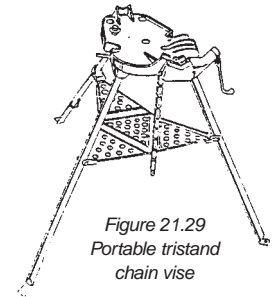

Figure 21.29 Portable trisland chain vise

- Mount the vise securely to prevent slipping or tipping over. Most tripod stands are equipped with a ceiling brace screw.
- Keep work close to the jaws of the vise.
- Support extra-long work.
- Keep the vise, especially the jaws, clean and oiled.

**Pipe and tube cutters**

The most common pipe and tube cutters have an alloy steel cutting wheel and two adjustable rollers. The hand units usually come in two sizes, up to 2" and 2" to 4". Usually larger tubes and pipes are cut with power cutters. Hand cutters for tubes up to 12" are available in hinged design as shown in Figure 21.30(b).

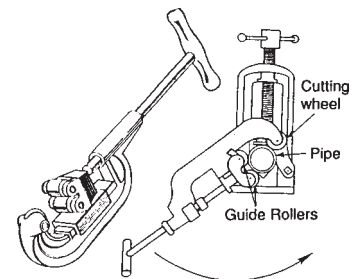

Fig. 21.30 (a): Cutting pipe or tube

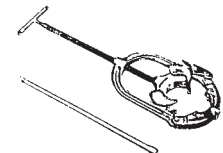

Fig. 21.30 (b): Hinged large tube cutter

In any case, it is important not to force too much pressure on the cutting wheel as it may shatter and cause dangerous fragments to fly off.

When setting up to cut, make sure to check the cutting wheel for nicks and make sure to keep the cutter perpendicular to the tube or pipe to ensure accurate tracking.

## Reamers

Reamers (Figure 21.31) are used to remove the burr that results from cutting pipe with roller pipe cutters. Be careful when using this tool with a power vise. There is always the potential for the reamer to dig into the pipe and twist the tool out of the worker's hands.

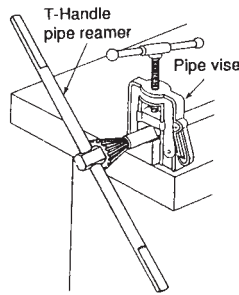
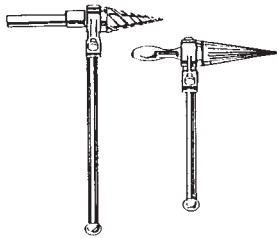

Figure 21.31: Using reamer to remove burrs from pipe or tube.

## Power Tools

### Basic Safety

Power tools used in construction are driven by gasoline, electricity, compressed air (pneumatic), hydraulic pressure, and explosive powder. Regardless of the source of power, these tools present hazards similar to and, because of their speed, often greater than hand tools. Typical injuries include cuts, burns, strains, and sprains. Causes of injuries include electric shock, flying particles and dust in the eye, falls, explosive atmospheres, and falling tools. These are all acute injuries produced by sudden trauma and are identified immediately with the event.

Chronic injuries must also be guarded against; such as musculoskeletal conditions like carpal tunnel syndrome or Raynaud's syndrome – white finger disease. These conditions can develop more subtly and prevention can involve awareness of a variety of precautions including tool selection, work schedules, and work practices.

Always wear eye protection. Flying particles and dust are always problems with power tools.

Wear hearing protection whenever there is chance of excessive noise exposure. Exposure to excessive noise can impair hearing and prolonged exposure can result in permanent damage to the hearing and eventually deafness.

Always disconnect the power on a portable power tool before changing or adjusting accessories such as drill bits and saw blades.

Never operate a power tool with the guard removed or improperly adjusted.

Power tools should not be left where there is a chance that the cord or hose may be pulled, causing the tool to fall. Cords and hoses left on the floor in high traffic areas may also create a tripping hazard. Cords or hoses that must cross access routes or roadways should be suspended above the ground or protected by wooden planks.

### General Guidelines

- Whenever possible, select tools with large handles relative to the tool body, to reduce vibration.

- Select tool handles covered with cork, rubber, or plastic bonded to steel to reduce vibration.
- Use tools with two handles to make holding and manipulation easier.
- Always refer to the operator's manual before using a tool the first time.
- Choose tools with a trigger strip rather than a trigger button. This spreads force over a greater area, reducing muscle fatigue (Fig. 21.32).
- Make sure there's adequate lighting for safe tool use.

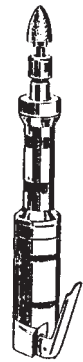

Figure 21.32

### Inspection and Repair

Frequent inspection of power tools is essential to keep hazards from developing. Inspection will also help to identify operating defects and possibly avoid costly breakdowns.

A regular schedule for inspection — daily, weekly, or monthly depending on requirements — will help to ensure that all power tools are in safe operating condition. Defective tools should be removed from service, tagged, and be either repaired or replaced.

Workers should be trained to inspect the tools they use and to report defects to their supervisor. The extent of the inspection and the responsibility for maintenance or repairs must be clearly communicated so there is no misunderstanding. Workers should not carry out makeshift repairs.

### Electric Power Tools

Types of injuries with electric tools include:

- major shocks that may cause a fatality
- electric flash burns
- minor shocks that may lead to injury from the tool itself or from resulting falls from ladders or platforms
- eye injuries from flying chips and cuttings
- gashes, cuts, and puncture wounds.



Figure 21.33

The potential for current to flow through a worker from a faulty tool is determined in part by working conditions. Wet or damp conditions can reduce resistance and can greatly increase the chance of current flow and injury from electric shock (Figure 21.33)

**Grounding** of electric power tools and the use of **ground fault circuit interrupters (GFCIs)** will protect the worker under most circumstances. GFCIs are required by law (Construction Regulation, section 195) wherever portable power tools are used outdoors or in wet conditions (Figure 21.34). GFCIs detect current leaking to ground from an electric tool or cord and shut off power before injury or damage can occur.

**Double-insulated tools** provide reliable shock protection without third-wire grounding. Tools with this type of protection are permanently marked **DOUBLE INSULATION** or **DOUBLE-INSULATED**. These tools have



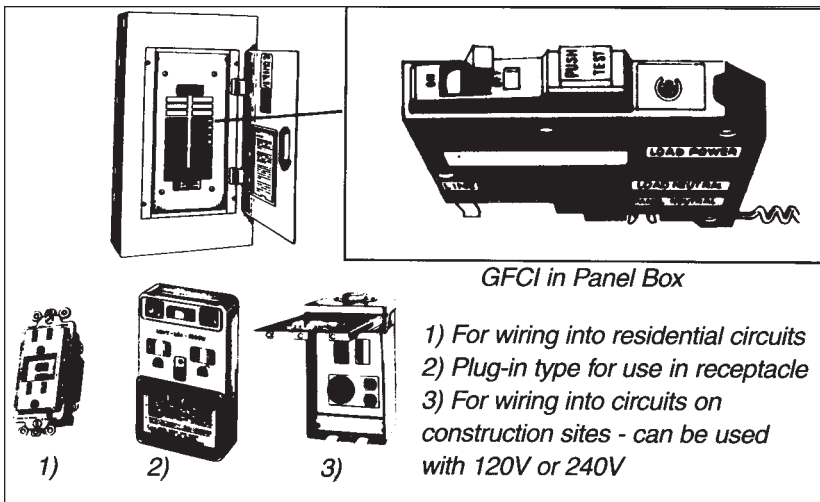

Figure 21.34

been tested and listed by Underwriters Laboratories and will carry the UL symbol. Many manufacturers are also carrying the symbol as shown in Figure 21.35 to identify double insulation.

On a double-insulated electric tool, an internal layer of protective insulation completely isolates the electrical components from the outer housing. Therefore, the third wire or ground wire is not needed.



Double Insulated  
Figure 21.35

- All tools should be tested regularly for effective grounding with a continuity tester (Figure 21.36).
- Tools should have deadfront plugs (Figure 21.37).
- Make sure the casings of double-insulated tools are not cracked or broken and are free of moisture, oil, and grease.

### Multimeters

Multimeters are used for testing circuits. Multimeters designed to meet the International Electro-technical Commission (IEC) 101 and Category (CAT) III standards, when properly operated, offer an acceptable level of protection recognized by the electrical industry in applications under 750 volts. CAT III devices afford more protection from high transient voltage spikes than do CAT II and CAT I designs.

Look for proof of independent testing, such as the CSA International (Canadian Standards Association) logo, along with CAT III on the equipment. Test levels should also be rated at the same or greater category and voltage than the multimeter.

For guidelines on standards, selection, and use, refer to the Electrical Hazards chapter in this manual.

### Electric cords and plugs

- Inspect regularly and make sure they are in good condition.
- Never cut off, bend, or cheat the ground pin on three-prong plugs.
- Use cords fitted with deadfront plugs (Figure 21.37). These present less risk of shock and shortcircuit

than open front plugs and prevent strain on current-

carrying components when the cord is accidentally pulled.

- Check extension cords and outlets with a circuit-tester (Figure 21.36).
- Don't use extension or tool cords that

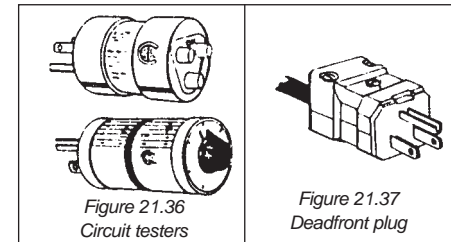

are defective or have been improperly repaired.

- Don't wire plugs into outlets. Disconnecting will take too long in an emergency.

- Protect cords from traffic.
- Extension cords should be kept clear of sharp objects, heat, oil, and solvents that may damage or soften the outer insulation. Do not use light-duty power cords.

### Electric Drills

Portable hand drills come in a variety of types and sizes. Figure 21.39 shows a typical light duty, variable speed drill.

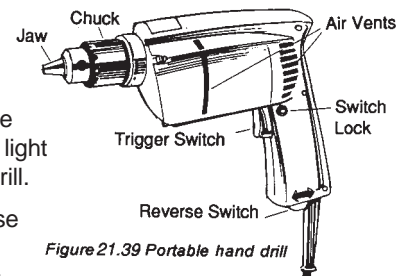

Figure 21.39 Portable hand drill

Electric drills can cause various accidents and injuries, including cuts, gashes, puncture wounds, and eye injuries from flying particles or broken bits.

Proper eye protection is essential. Material being drilled should always be clamped or well secured to prevent whipping should the bit bind in the hole (Figure 21.40).

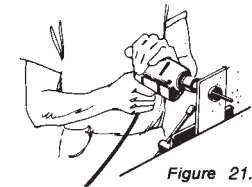

Figure 21.40

Standing on a ladder to drill a hole in a wall or overhead can be hazardous

(Figure 21.41) as well as hard on the shoulder. The top and bottom of the ladder must be secure to prevent the ladder from slipping when the operator puts pressure on the drill. Never reach out to either side of the ladder. Overreaching can cause the ladder to slide or tip. When using any power tool from a ladder, never support yourself by holding onto a pipe or other grounded object.

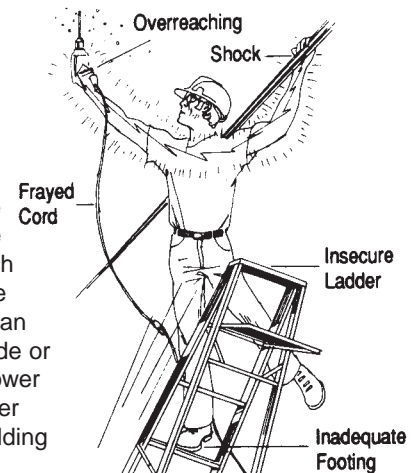

Figure 21.41

Electric current can travel from the hand holding the tool through your heart to the hand holding the pipe. A minor shock can make you lose your balance. A major shock can badly burn or even kill you.

Always be sure that the switch is off before plugging in the drill.

Make sure the shank of the attachment is tight and square in the chuck and running true before starting the drill.

Punch or drill a pilot hole in the work so that the bit won't slip or slide when you start drilling. Align the drill square with the hole — Figure 21.42.

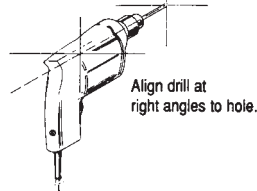

Figure 21.42

## Impact or Hammer Drill

Using an impact or hammer drill (Figure 21.43) requires considerable control. Feed the attachment slowly and carefully into the material or the drill may jam and stop suddenly, severely twisting or breaking your arm. When drilling into floors, ceilings, and walls, beware of plumbing — and wiring!

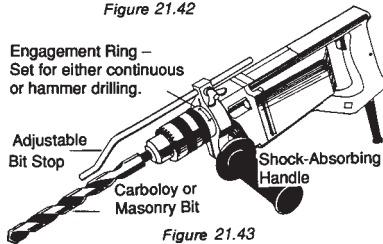

Figure 21.43

## Drill Presses

On many jobs, either conventional drill presses or the more mobile electromagnetic drill presses are used. They permit more accurate drilling.

- Make sure no loose hair or loose or torn clothing can be caught in the drill bit and cause serious injury.
- Before doing any drilling on a workpiece on a conventional drill press, make sure the work is securely clamped to the drill table.
- Electromagnetic ("mag") drills are only "attached" if switched on.
- "Mag" drills if "attached" on vertical or overhead ferrous surfaces must also be secured by safety chain in case of power loss.

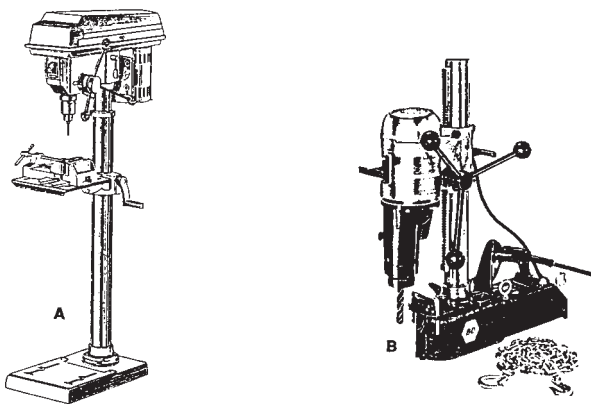

Figure 21.44 Drill Presses A) Conventional

B) Electromagnetic

## Power Saws

Used on construction sites, power saws of all types are a regular source of injury. Basic safety considerations with any power saw include the following points.

- Wear protective clothing and equipment. Eye protection is essential — a full face shield is recommended because of the potential for flying pieces, not just small particles. Hearing protection should also be worn.
- Where ventilation is inadequate, wear a dust mask for protection against dust. Exposure to dust from cutting metal, concrete, or other materials may cause respiratory problems over time.
- Electric saws operated outside or in wet locations must be protected with a ground fault circuit interrupter (GFCI).
- Never wear loose clothing, neck chains, scarves, or anything else that may get caught in the saw.
- Leave all safety devices and guards in place and properly adjusted on the saw.
- Change and adjust blades with the power OFF. Disconnect the saw from the power source.

Chop saws are becoming more popular among many trades in construction (Figure 21.45). They provide quick, economical cutting of various materials.

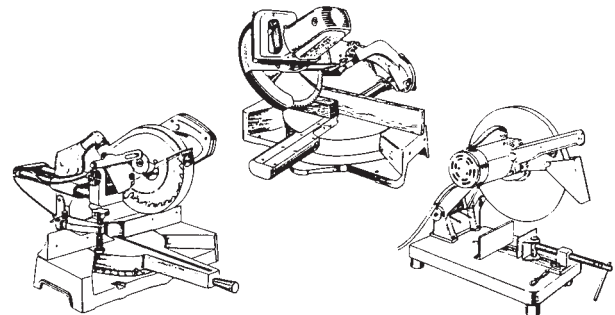

Figure 21.45

As with all power equipment, chop saws pose a serious hazard for the unwary or untrained operator. Most of these saws are equipped with abrasive wheels for quick cutting through metal and other materials.

- Select the proper abrasive cutting wheel for the material being cut. For metals, use aluminum oxide. For masonry, stone, and concrete, use silica carborundum.
- Position material to be cut at 90 degrees to the blade. Support the other end to prevent the blade from binding.
- Do not rush cutting. Let the wheel cut without burning or jamming.
- When cutting is complete, let the blade stop before moving material.
- Keep the saw in good repair with the blade guard in place and working properly. Tighten any loose parts and replace any broken or damaged components.

Quick-cut saws are widely used for cutting sheet metal, light steel angles, and channels as well as aluminum, concrete, and masonry products (Figure 21.46). They are high-powered compared to similar tools. Hazards include high-speed rotation, blade exposure during operation, and exhaust from the internal combustion engine — the usual power source.

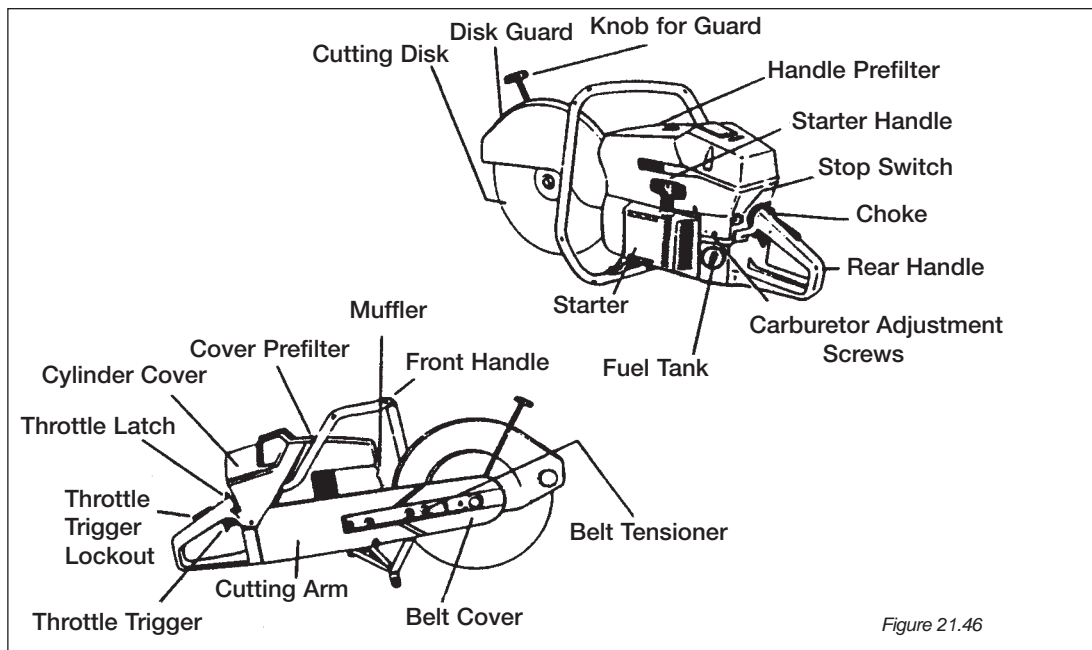

Figure 21.46

Quick-cut saws also create clouds of dust and hot sparks when dry-cutting metal products, especially steel.

Injuries can result from cuts, kickback, exposure to carbon monoxide fumes, dust exposure, burns, flying particles in the eye, and other injuries from flying material when work is not secured for cutting or when blades fly apart.

Hazards with quick-cut saws can be controlled by

- operators trained to use the saws properly and to wear the right protective equipment (full face shield and hearing protection.)
- saws kept in good working condition, equipped with the proper blades or abrasive disks, and used with all guards in place
- work secured to keep it from shifting during cutting.

Operators of quick-cut saws should be instructed in the care, maintenance, and operation of the tool. The operating manual should be kept on the job and read by users. Time spent on instruction will reduce accidents and injuries as well as extend the service life of the saw.

As a minimum, the operator of a quick-cut saw should be instructed in

- care of the saw
- installing disks and blades
- mixing fuel and fuelling the saw
- starting the saw
- supporting and securing the work to be cut
- proper cutting stance and grip
- proper cutting techniques for different material
- respiratory protection against dust
- inspection and storage of abrasive disks.

In confined areas, make sure that ventilation is adequate. Gasoline-driven saws release carbon monoxide



Figure 21.47

gas — odourless, colourless, and highly toxic.

For safe starting, set one foot on the rear handle, put one hand on the top handle to lift the blade off the surface, and use the other hand to pull the starter cord (Figure 21.47).

Once the saw is running, release the throttle and make sure the engine drops to idle without the disk or blade moving.

Run the engine at full throttle and let the disk or blade run freely to make sure it turns on the arbor without wobbling or vibrating.

The saw is powerful enough to throw material around unless it is securely held and supported. Standing on material to hold it down is not recommended.

Kickback can happen extremely fast and with tremendous power. If the segment of the disk or blade shown in Figure 21.48 contacts the work, the disk or blade starts to climb out of the cut and can throw the saw up and back toward the operator with great force.

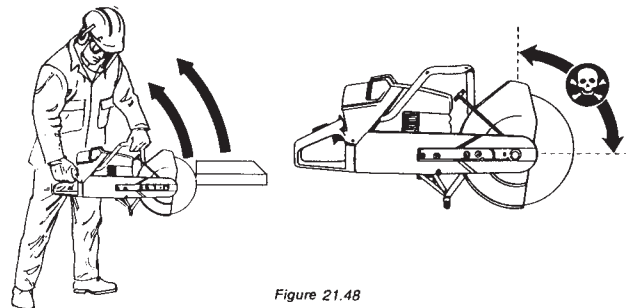

Figure 21.48

Take the following precautions

- Run the saw at full throttle.
- Do not cut above chest height.
- When re-entering a cut, do so without causing the blade or disk to pinch.
- Secure and support material at a comfortable position for cutting. Make sure that material will not move,

- shift, or pinch the blade or disk during cutting.
- Keep steady balance and solid footing when making cut.
- Use both hands to control the saw. Maintain a firm grip with thumb and fingers encircling the handles.
- Never let the upper quarter segment of the blade or disk contact the material.
- Select the right blade for the job (Figure 21.49).

### Abrasive Disks - Types and Uses

Type	Uses	Materials
Concrete	All-around use, most economical cutting concrete and masonry. Water-cooling is recommended to increase disk life and reduce cost.	Concrete, stone, masonry products, cast iron, aluminum, copper, brass, cables, hard rubber, plastics.
Metal	Primarily for steel, not suited for masonry products. Water-cooling is not recommended with metal abrasive disks.	Steel, steel alloys, other hard metals such as monel and iron.

Figure 21.49

In addition to the protective equipment that is mandatory on construction sites, operators of quick-cut saws should wear snug-fitting clothing, hearing protection, eye and face protection, and heavy-duty leather gloves (Figure 21.50).

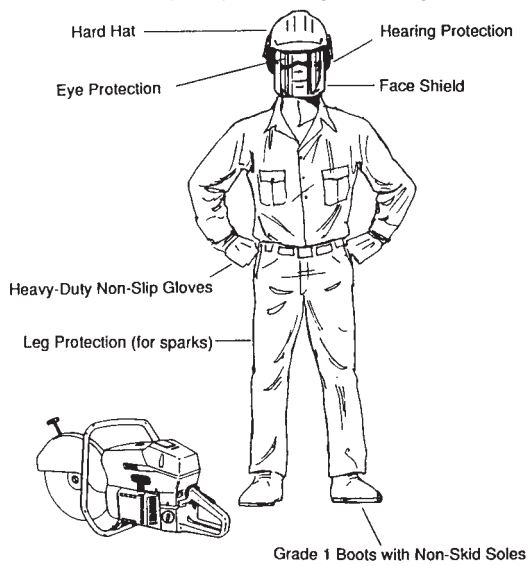

Figure 21.50

For general dust hazards, a half-mask cartridge respirator with NIOSH approval for dust, mist, and fumes should provide adequate protection when properly fitted and worn.

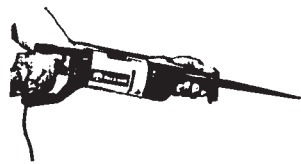

Figure 21.51 - Reciprocating Saw

### Power Hacksaws

Power hacksaws come in two types; straight blade (reciprocating saw) and continuous blade (portable band saw) as are shown in Figures 21.51 and 21.52.

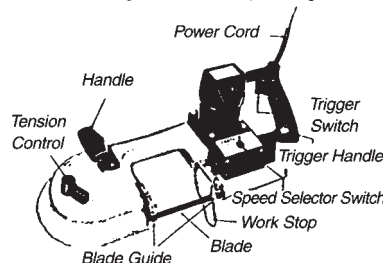

Figure 21.52 - Portable Band Saw

When using a power hacksaw, observe the following.

- Wear eye protection.
- When starting a cut with a hand-held saw, hold it above the work, turn it on, and lower it carefully onto the work (avoid plunge cuts).
- Always start the cut off an edge, never against it.
- Always keep the blade guard in place and the blade sharp.
- Keep hands away from the cutting area.
- Make sure the material being cut is secure to prevent movement.
- Stay clear of end pieces that may fall after being cut off.
- If using the tool as a portable unit, take extreme caution when cutting conduit or pipe blindly. Make sure it doesn't contain electrical wires, gases, or chemicals that could produce a hazard.

### Portable Nibblers

Portable nibblers, or power metal shears, will cut sheet metal up to about 1/4" thick. Either electric or pneumatic, they have one stationary blade and one powerful shearing blade. Stationary tools will cut heavier sheet or plate. Always secure material tightly before cutting and check for clearance under the work. See Figure 21.53.

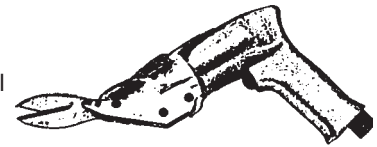

Figure 21.53 - Portable Nibblers

### Portable Grinders

Grinding wheels, portable buffers, and wire brushes are a constant source of flying particles and require special caution. The storage, mounting, and operation of grinding wheels calls for thorough training. Figure 21.54 shows types of portable grinders in common use: straight grinders, with stones half an inch wide or more, by 4 to 8 inches in diameter; and angle, or vertical, grinders with abrasive or sanding disks or cup stones.

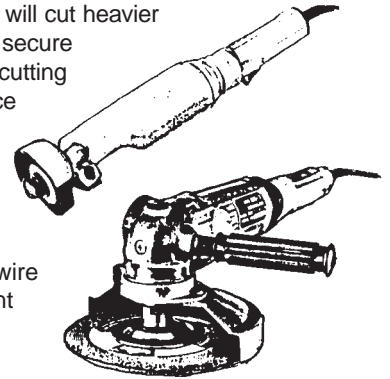

Figure 21.54 Types of portable grinders

### Safety in using a portable grinder

- Always wear eye protection.
- Ring-test abrasive wheels before use.

### Ring Test

- Clean material from wheel.
- Let wheel dry before testing.
- Tap wheel with something non-metallic such as the handle of a screwdriver.
- Tap 1/2" from outside edge.
- Rotate wheel 45 degrees and repeat test.
- A sound, undamaged wheel will give off a clear metallic ring. A cracked wheel will give off a dull sound with little or no ring.



- Never exceed the safe grinding in rpm for a stone or disk, which should be specified on the manufacturer's label. Make sure the maximum rpm of the grinder doesn't exceed the stone speed. Excessive speed can cause disks and stones to disintegrate with the potential for causing a serious injury.
- Always unplug the tool before making grinder/cutter installations.
- Make sure that the grinding wheel is installed according to the manufacturer's instructions. Use the proper hardware (safety flanges, nuts and blotters) as recommended for holding the wheel in position.
- Make sure that safety guards are in place and properly adjusted before operating.
- If you drop a portable grinder or a wheel, inspect it very carefully for damage.
- Wear hearing protection, especially for extended operation. Wear respiratory protection.
- Change disk or stone as recommended by manufacturer. Excessively worn disks and stones can shatter in use.
- Grind only on the face or outer circumference of the grinding wheel unless it is specifically designed for side grinding.
- Gloves, aprons, and foot protection may be advisable for some work, especially if hot sparks are being generated.
- Always stand aside when starting a grinder, especially with a newly mounted wheel. Hold it away from you until the tool has run at operating speed before contacting the work. This can prevent injury from a faulty wheel blowing apart.
- Use light pressure when starting the grinding, especially with a cold wheel — too much pressure on a cold wheel may cause failure.
- Don't wear loose clothing when grinding.
- Do not use grinders in the vicinity of flammable materials.

### Pencil Grinders and Rotary Files

These are normally straight die grinders (some have right-angle drive) which accept compatible cutters (files or burrs) or abrasive grinding points of small diameter, normally under 2 inches.

Common types include **pencil grinders** and **rotary files**. These grinders operate at high speeds and must be used with caution. The small-diameter tools run up to about 80,000 rpm and the larger at about 20-30,000 rpm. The files or burrs are sharp and can easily cut you, even when static.

Precautions are similar to those for other grinders, but these tools are often unguarded — an added hazard.

- Use only the accessories recommended by the manufacturer and ensure they are speed-rated at least as high as the no-load RPM on the tool's nameplate. The wrong accessory, if rotated too fast, may shatter during use.
- Use grinding wheels when working with hard materials. Rotary files are used for soft materials such as aluminum, brass, and copper. Using grinding

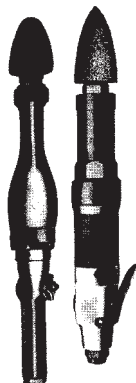
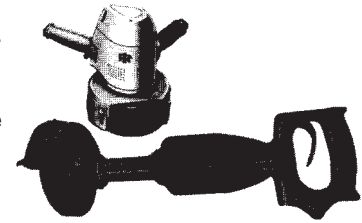

Figure 21.55 – Straight Grinders

wheels on soft materials can cause build-up and excessively load the wheel, with the possibility of wheel disintegration.

- Never over-tighten the collet; it can damage the collet, cutter or wheel. If the tool doesn't run smoothly, the cutter may be out of balance. Replace it.
- Excessive pressure can bend or break the collet, mandrel, or wheel/cutter. If the grinder runs smoothly without load, but not smoothly under load, too much pressure is being used.
- Maintain a firm grip on all grinding tools. Always keep the tool pointing away from you. Never use a rotary die grinder with the cutter towards you. A slip could cause serious injury.
- Use a vise or clamp to hold the workpiece securely. Never hold a small workpiece by hand.



Angle Grinders

### Air-Powered Tools

Many different types of tools are powered by compressed air. They are fast, powerful, and ideal for repetitive tasks such as scaling, chipping, and tube shaping or fitting, as well as a variety of general construction tasks such as breaking concrete or nailing. There are pneumatic equivalents for most electrical tools, including grinders, drills, and impact wrenches. Some pneumatic tools have no electrical equivalent, including needle scalers, rotary impact scalers, and chipping hammers.

Pneumatic tools can operate (when used with a portable compressor) in locations remote from another source of power. Overloading will stall the tool without damaging it; there's no shock hazard; speed control is variable from zero to maximum; and fire and explosion hazards can be reduced in some environments where sparking can be a problem.

### Air Compressors

Powered by a combustion engine or electric motor, air compressors supply the air for the tool. Keep the manual with the machine and follow its directions. Check the maintenance and setup requirements and stick to a regular maintenance schedule.

There are basic precautions which must be followed for compressors.

- Inspect before use, check hoses and fittings, and never use a damaged unit.
- Keep the belt guard in place.
- When using a gas or diesel powered unit, make sure there is adequate ventilation and avoid inhaling exhaust gases.
- In cold weather, moisture in the air lines can freeze, reducing the efficiency of the equipment and producing potential hazards. Anti-freeze systems are available in addition to the cold weather precaution given below.

**Air hoses** should be kept clear of traffic and not present tripping hazards. A hose that is left on the floor should be

protected against damage by running planks along either side of it. Where possible, suspend hoses over walkways, traffic routes, and work areas, but take care that hoses do not get caught on passing vehicles.

Occasionally workers suffer injuries when compressed air is used to blow dust and dirt from the work area or from clothing. Compressed air can enter the skin and bloodstream with disastrous results. It can also blow particles and dust into the air at high velocity, endangering eyes and lungs. To clean away dust, use a brush or vacuum instead.

Always secure hose connections with wire, safety clips, or chain to prevent whipping, except when automatic couplers are used.

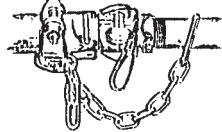

Never kink hose to stop air flow. Turn off the pressure to hoses when the system is not in use.

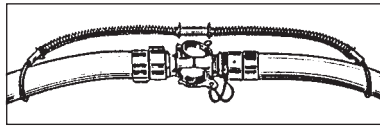

In cold weather, after the system is shut down and bled, air hoses should be stored overnight in a warm place so that any residual moisture cannot condense and freeze. If hoses are left out, ice can form inside. On startup they may be plugged and ice chips can be fired out of the end of the hose. Injuries have resulted from workers being struck while looking down the plugged line, or being struck by objects used to clear the line. In very cold conditions, a spare set of hoses is a good idea so that one set can always be stored and dry.

### Injuries Caused by Compressed Air

**Air embolism** can lead to death. If compressed air from a hose or nozzle enters even a tiny cut on the skin, it can form a bubble in the bloodstream with possibly fatal results.

**Physical damage** – compressed air directed at the body can cause injuries, including damage to the eyes and ear drums.

**Flying particles** can accelerate to well over 70 mph when compressed air is used to blow off dust, metal shavings, or wood chips. These particles carry enough force to penetrate the skin.

**Airborne contaminants** can include silica and other substances hazardous to the respiratory system.

### Pneumatic impact tools

When using air-powered tools, use only the attachments designed for them. For example, with impact wrenches, use only impact sockets and adapters manufactured for this use - they are normally marked, of a dull black colour, 6-point, and of heavier wall construction than hand sockets. Hand sockets, if used, could shatter and cause injury. Always check sockets for wear or damage; sockets in poor condition could also shatter.

When using larger impact wrenches, don't try to work alone; always consider whether you need help. A second worker is often needed for the backup wrench while

tightening to avoid injury due to the torque developed by an impact wrench.

Some tools have a high noise level — for instance, impact drills. To prevent hearing loss, always wear hearing protection.

Match the speed rating of any attachments to the tool speed. Too fast or too slow a speed can damage attachments, break off fragments, and cause injury.

Before start-up, check the couplings and fittings, open the control valve momentarily, connect the hose and blow it out by opening the valve momentarily to remove moisture and dirt, then clean the nipple before connecting the tool. Set air pressure according to manufacturer's specifications and open gradually.

Make sure that attachments on pneumatic tools are secured or locked according to manufacturer's instructions.

Pneumatic impact tools require regular inspection by qualified persons. Replace worn-out absorption pads and springs. Too much vibration of the tool can damage nerves in fingers, hands, and other body parts. This is called "White Finger disease" or Raynaud's Syndrome.

### Grinders

For information on the hazards and safe use of pneumatic grinders, refer back to the section on electric grinders.

Apart from the different hazards connected with their power sources, air- and electric-powered grinders present the same basic problems.

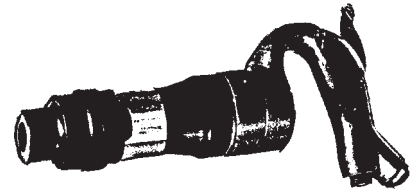

Figure 21.56 Pneumatic chipping hammer

### Chipping hammers and chisels

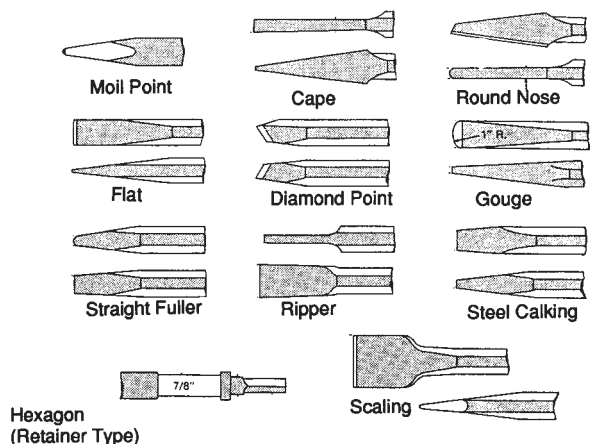

Figure 21.57 Chisel types

Chipping hammers, or chippers (Figure 21.56), are versatile tools for a number of uses with a variety of chisel tips available for attachment (Figure 21.57).

Safe practices for chippers include the following.

- Always wear eye protection when using a chipping hammer; make sure anybody else in the immediate area also has eye protection.

- When working, never point the chipper so that anybody might be hit by an accidentally ejected bit.
- Toward the end of a cut, ease off on the throttle lever to decrease the intensity of the blows to reduce the possibility of a chip or the tool flying.
- If the hammer has to be laid down, remove the attachment to prevent it from being accidentally ejected if the tool is unintentionally started.

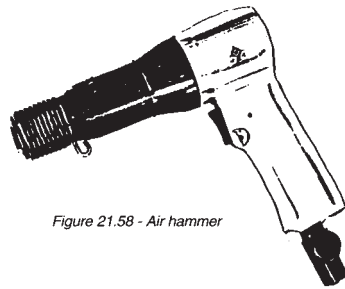

Figure 21.58 - Air hammer

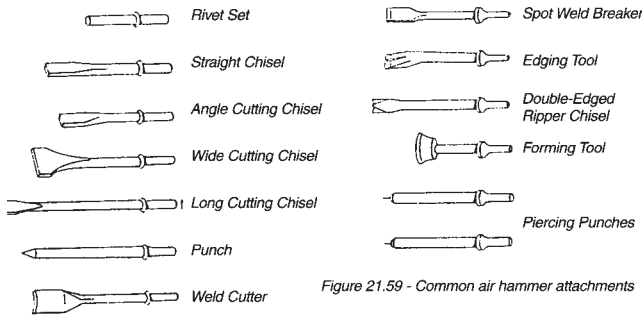
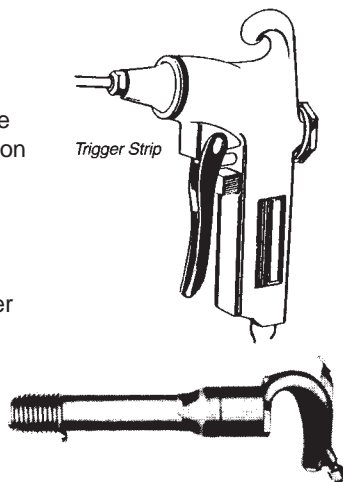

Figure 21.59 - Common air hammer attachments

**Air hammers** are small multi-purpose tools. Figure 21.59 shows some common air hammer attachments.

**Safety Tip**

Choose tools with a trigger strip rather than a trigger button. This spreads force over a greater area, reducing muscle fatigue.



**Rivet guns**

A plunger inside the barrel strikes the rivet tool, causing it to shape the rivet head. Since the plunger is free to come out, it should be removed to prevent loss or discharge when the tool is put aside.

**Air Scalars**

The air scaling gun is a lightweight, highspeed tool suitable for chipping, scaling, and removing caulking, rust, scale, flux, spatter, etc. from all types of surfaces and shapes.

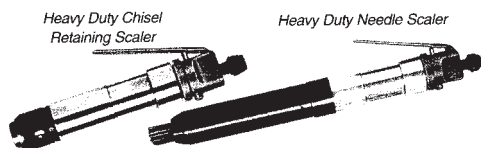

Figure 21.60 - Air Scalars

A needle scaler attachment is commonly used by boilermakers (Figure 21.60). Because of its configuration of many needles rapidly impacting individually, it is useful for cleaning all kinds of surfaces, including irregular ones, since it automatically fits the irregular contours.

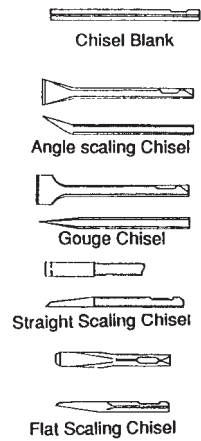

Figure 21.61 Common attachments for air scalars.

Besides the needle scaler attachment, there are other chisels that work well with air scalars (Figure 21.61). Some of these chisels have an offset blade at an angle to enable access into awkward corners. These are not intended to cut and are therefore sharpened to a dull edge to clean out slag in corners without undercutting.

**Pipe Power Tools**

**Power Threading Machines** (Figure 21.62).

These are designed to let the operator cut, ream, and thread pipe of various sizes all in one power machine. The machine must be treated with respect. Potential hazards include:

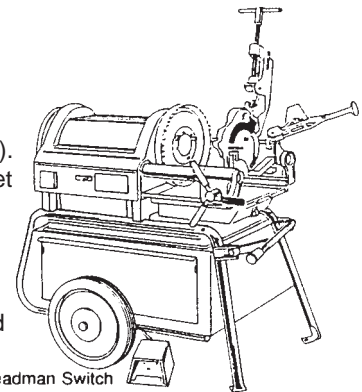

Figure 21.62

- catching clothing, gloves, or cleaning rag in revolving parts
- being struck by flying metal chips
- using a rag to clean oil from threads while machine is turning
- wearing loose-fitting clothes
- pipe wrench locking on pipe while reversing previous operation
- losing grip or footing because of oil and debris
- failure to install and use the deadman switch.

**Roll Groover**

This machine forms standard roll grooves in steel, stainless steel, and aluminum pipe. Figure 21.63 shows a heavy-duty roll groover designed for 2-inch to 8-inch schedule 40 steel pipe (up to 12-inch for schedule 20 or lighter wall pipe).

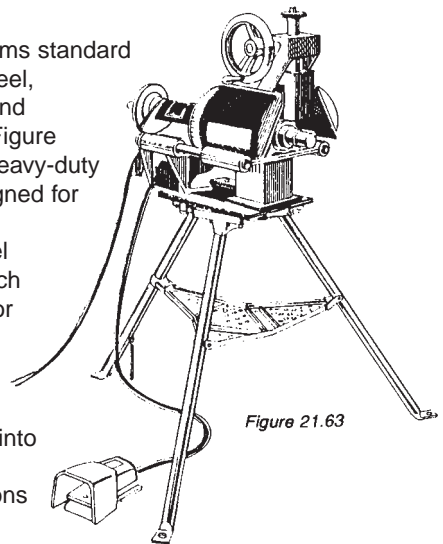

Figure 21.63

Grooves are formed by a grooving roll fed into a drive roll to the exact specifications required for mechanical

coupling systems. The roll groover can be mounted on a power drive or threading machine.

## Set-up

- Read and follow the operator's manual and the information on the machine.
- Know the location and function of each control before using the machine.
- Wear snug-fitting clothes, safety boots, hard hat, and eye protection. Cover or tie up long hair. Do not wear gloves, unbuttoned jackets, loose sleeve cuffs, neckties, scarves, rings, watches, or other jewelry.
- Wear hearing protection — ear plugs or muffs — if you use the machine daily or in a noisy area.
- Use only an approved three-wire cord with a three-prong plug in a grounded receptacle. Replace or repair any damaged, frayed, broken, or worn cords.
- If an extension cord is required, it must be three-wire with three-prong plug and three-pole receptacle. Make sure the cord is large enough to prevent excessive voltage drop.
- Make sure that switch is in the OFF position before you plug in the power cord.
- Connect the machine to an AC power supply that matches the nameplate specifications.

## Operation

- Clear the roll groover of all objects such as tools and material before turning it on.
- Keep guards in place. Never operate the machine with guards removed or disarmed. Your fingers can get caught between the grooving and drive rolls.
- Operate the roll groover from the switch side only.
- Keep good footing and balance. Do not operate the machine when you are tired.
- Do not use the machine in damp or wet conditions. Do not expose to rain.
- Unplug power cord when you are adjusting or servicing the machine and changing accessories.
- Use the footswitch. It lets you shut off the motor simply by removing your foot.

**Warning:** clothing caught in the roll groover will continue to wind up, pulling you into the machine. Because the machine has high torque, the clothing itself can bind around your arm or other body parts with enough force to crush or break bones.

- Make sure that you can quickly remove your foot from the footswitch.
- Keep other workers out of the work area. Keep the area clean, dry, and well lighted.
- Do not reach across the machine.
- Properly support the work on a pipe stand.

## Maintenance

- Follow manufacturer's instructions for cleaning, servicing, and inspection.
- Keep handles dry, clean, and free of grease.
- When not in use, store the roll groover in a locked area secure from

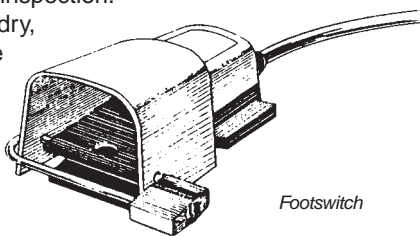

Figure 21.64

people unfamiliar with the machine.

- Keep footswitch in working order. When not in use, lock the switch to avoid accidental start-up (Figure 21.64).

## Pipe Preparation Tools

Some power tools are manufactured for specific piping systems. For instance, the Victaulic Pressfit System for joining pipe with specially designed couplings uses a power crimping tool (Figure 21.65). It is designed for schedule 5 black or galvanized steel pipe prepared to meet Victaulic specifications.

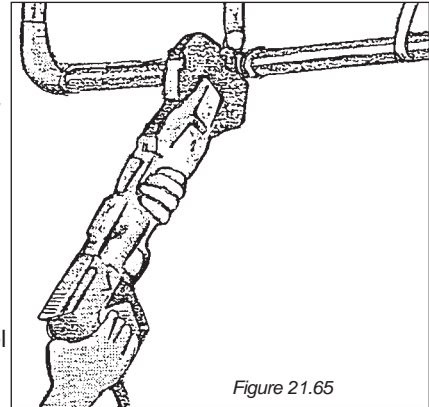

Figure 21.65

The T-Drill T-Less tube branching system mechanically forms outlets in copper tubing and eliminates the need for tee and cross fittings. The T-Drill (Figure 21.66) drills the required hole in the pipe and forms a collar to accept the branch pipe. The tube end notcher cuts and dimples the branch tube to limit insertion depth. The joint is then brazed.

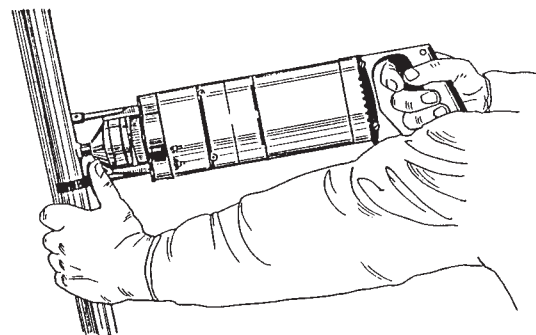

Figure 21.66

Victaulic crimpers and T-Drills are being used more and more in automatic sprinkler system installation. Take the following precautions.

- Read and understand all instructions in the manufacturer's operating manual before operating or servicing the tools.
- Inspect all movable parts before starting the tools. Check for obstructions and proper installation of components.
- Disconnect tools from power source before changing accessories or servicing. Be sure switch is off before plugging in the tools.
- Use only replacement parts supplied by the manufacturer.
- Keep work area clean.
- Guard against shock. Prevent body contact with grounded surfaces. Always use a ground fault circuit interrupter.
- Do not carry live tools with your finger on the switch.



- Keep unauthorized personnel out of the work area.
- Store tools in a dry location in a locked container.
- Do not force or overload the tool.
- Wear adequate eye protection.
- Use the tools only for their intended purpose.
- Do not operate the tools while wearing loose clothing, jewelry, or anything else that could get caught in moving parts.
- Never carry tools by the cord or yank the cord to disconnect the tool from the receptacle. Protect cord from heat, pinch points, and sharp edges.
- Use clamps, vice, or secure pipe hangers to hold work in place.
- Do not overreach. Keep proper footing and balance at all times.
- Keep tools clean and lubricated. Repairs should be done only by an authorized service shop. Inspect and replace damaged extension cords. Keep handles clean, dry, and free from oil and grease.
- Do not operate tools near flammable liquids or in explosive atmospheres.

## Powder-Actuated Tools

Referred to as *explosive-actuated* or *powder-actuated*, these tools use a powder charge to fire a fastener into hard materials such as concrete, mild steel, and masonry (Figure 21.67). They provide a fast, efficient means of fastening certain combinations of materials.

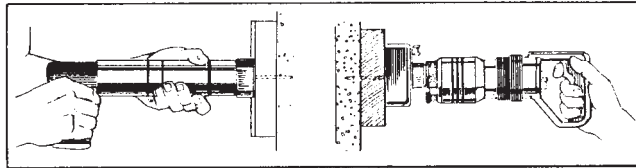

Figure 21.67

Used improperly, powder-actuated tools present obvious hazards. For that reason, most jurisdictions — including Ontario — require that operators be trained before using these tools.

**Flying particles** are the major hazard. On impact, materials may break up, blow apart, or spall off. This often happens when fasteners are fired too close to a corner of masonry or concrete (Figure 21.68) or when they strike materials such as glazed tile, hollow tile, or thin marble tile.

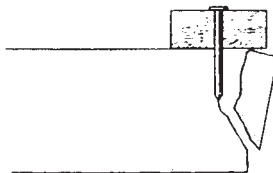

Figure 21.68

**Ricochets** usually result when the tool is not at right angles to the material or the fastener hits a particularly hard base material such as stone or hardened steel. Always check the base material to ensure that it will safely accept the fastening device.

**Noise** is extreme when powder-actuated tools are fired. Operators and others in the area should wear hearing protection. This is especially important when the tool is operated in a confined space.

**Sprain and strain injuries** usually result from using the tool repeatedly in awkward, cramped, or unbalanced positions. Operators should try to work from a balanced position on a solid surface.

**Explosions and fires** are always a risk when the tools are used where atmospheres may be flammable. The work area must be well ventilated, mechanically if necessary, as in confined spaces.

**Blow-through** results when the base material does not offer enough resistance and the fastener passes completely through and flies out the other side. This is particularly dangerous when fasteners blow through walls, floors, or ceilings where other trades may be working on the opposite side. Check the other side of walls, ceilings, and floors before firing and keep people clear if necessary.

**Protective equipment** for the operator of a powder-actuated tool should include hearing protection, eye protection, and a face shield. Heavy shirts and pants provide some protection against ricochets and fragments of material or fasteners.

**High velocity** powder-actuated tools use the exploding cartridge to propel the fastener directly rather than by a piston. These tools are rarely used in construction, except in special cases to penetrate thick steel or very hard material. These applications are usually military, salvage, or underwater. No one should operate high-velocity tools without special training.

**Low velocity** tools are the most common for construction. The explosive charge drives a piston which in turn drives the fastener (Figure 21.69).



Figure 21.69

Many different low velocity tools are available. Some are specialized for certain trades such as drywalling. Others are fitted with various pistons, base plates, spall stops, and protective shields for heavier-duty work.

Generally, low velocity tools should only be used on mild or structural grade steel no thicker than 7mm (1/4").

**Fasteners** used with powder-actuated tools such as studs and pins (Figure 21.70) are made of special steel to allow them to penetrate materials without breaking or bending.

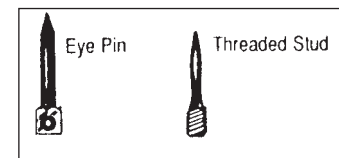

Figure 21.70

The fastener is fitted with a tip or eyelet as a guide. This aligns the fastener on the tool as it is being driven. It is also used to retain the fastener in the tool.

Generally, fasteners should not be used on hard, brittle, or glazed materials such as cast iron, marble, tiles, and most stone. The fastener will either fail to penetrate and ricochet or the base material will shatter or spall.

Materials whose hardness or ductility is unknown should be tested first. Try to drive a pin into the material with a standard hammer. If the pin point is blunted or fails to penetrate at least 2mm (1/16"), don't use a powder-actuated tool.

**Cartridges** are available in various powder loads. Manufacturers may recommend cartridges for certain applications but recommendations cannot cover every possibility and testing may be required with unfamiliar material. The general rule is to start with the weakest cartridge and increase one load number at a time to reach the penetration required.

Too strong a charge may shatter material, ricochet, or blow through. Standard loads, colour coding, and velocities for cartridges are listed in Figure 21.71.

### Colour Identification of Powder Load Strengths

Load Number	Cartridge Case Colour	Powder Load Colour	Nominal Velocity	
			m/s	ft/s
1	Brass	Grey	91.4	300
2	Brass	Brown	118.8	390
3	Brass	Green	146.3	480
4	Brass	Yellow	173.7	570
5	Brass	Red	201.2	660
6	Brass	Purple	228.6	750
7	Nickel	Grey	256.0	840
8	Nickel	Brown	283.5	930
9	Nickel	Green	310.9	1020
10	Nickel	Yellow	338.3	1110
11	Nickel	Red	365.8	1200
12	Nickel	Purple	393.2	1290

Figure 21.71

Misfired cartridges can be dangerous. Take the following precautions.

- Hold the tool against the material for at least 30 seconds in case firing is delayed.
- Remove the cartridge from the tool with the tool pointed toward soft material such as wood.
- Regulations require that a misfired cartridge be placed in a container of water.
- Never throw a misfired cartridge in the garbage.

### Explosive-Actuated Tools — General Safeguards

- Explosive-actuated tools should not be used, handled, or stored carelessly.
- Don't fire fasteners through pre-drilled holes for two reasons:
  - 1) Unless the fastener hits the hole squarely, it will probably shatter the edge.
  - 2) The fastener gets its holding power from compressing the material around it. A pre-drilled hole reduces this pressure and therefore the fastener's power.
- Because pressure must be applied to the material into which a fastener is being driven before the tool will fire, working from a ladder is not recommended. For work overhead or at heights, operate the tool from a scaffold or other approved work platform.
- Do not leave the tool unattended unless it's locked in a box.
- Load the tool immediately before firing. Don't walk around with the tool loaded.
- Do not use powder-actuated tools in areas where the atmosphere may be explosive or flammable.

The **Regulations for Construction Projects** define the minimum requirements for the operation, maintenance, storage, and training of workers. Refer to the regulations before operating any powder-actuated tool.