

## 30 MOUNTING AND DISMOUNTING

Each year, workers are hurt while getting on or off trucks, backhoes, and other construction equipment. Learn the safe way to mount and dismount.

### Three-point contact

When getting on or off equipment, you need three points of constant contact with the machine. That means one hand and two feet, or two hands and one foot – **at all times**.

Anything less, and you're risking a fall.

Three-point contact forms a triangle of anchor points which changes in form while you mount or dismount (Figure 1). You have the most stability when the centre of this triangle is close to your centre of gravity. Your weight should be evenly distributed among the three contact points. This means that you should avoid sideways movement because it can put you off balance.

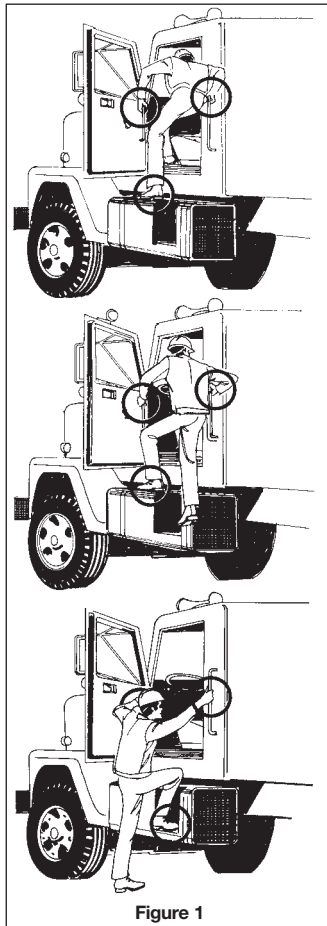

Figure 1

### Remember

- ✓ always face in towards the machine or ladder
- ✓ mount and dismount only when the equipment is standing still
- ✓ break three-point contact only when you reach the ground, the cab of the vehicle, or a stable platform
- ✓ take your time
- ✓ take extra care in wet, snowy, icy, or other dangerous weather conditions
- ✓ avoid wearing loose or torn clothing that can catch on the equipment
- ✓ get on or off at the safest access position (normally designed by the manufacturer)
- ✓ where necessary, retrofit equipment to provide safe access.

The Construction Regulation states that construction equipment must have a means of access to the operator's station that will not endanger the operator, and must have skid-resistant walking, climbing, and work surfaces.

Ensure that your equipment complies with the law. And keep runningboards, treads, steps, footholds, and platforms clear of mud, ice, snow, grease, debris, and other hazards. Housekeeping keeps you and your co-workers safe!