

20 LADDERS

INTRODUCTION

Every year in the Ontario construction industry more than 800 lost-time injuries are caused by ladder accidents. Many of these accidents involve falls resulting in serious injuries and fatalities. Falls from ladders are common to all trades and pose one of the most serious safety problems in construction. The following are major causes of accidents.

- Ladders are not held, tied off, or otherwise secured.
- Slippery surfaces and unfavourable weather conditions cause workers to lose footing on rungs or steps.
- Workers fail to grip ladders adequately when climbing up or down.
- Workers take unsafe positions on ladders (such as leaning out too far).
- Placement on poor footing or at improper angles causes ladders to slide.
- Ladders are defective.
- High winds cause ladders to topple.
- Near electrical lines, ladders are carelessly handled or improperly positioned.
- Ladder stabilizers are not used where appropriate.

To assist supervisors and foremen in preventing such accidents, this chapter provides guidelines for selecting, setting up, maintaining, and using ladders. Because ladders are the most common type of access equipment in the construction industry, thousands are used every working day. As a result, there are many thousands of hours of exposure to ladder hazards every week.

The extensive exposure, the high fatality rate, and the large number of lost-time injuries as well as the associated costs and suffering from ladder accidents justify increased training of the workforce and better supervision of ladder use. Worker training alone will not yield sufficient improvement. Any significant reduction in ladder accidents will require regular supervisory reinforcement of training as well as improved site control of operations involving ladders.

STANDARDS AND MATERIALS

Standard manufacturing specifications exist for most types of ladders. CSA Standard Z11 sets out standard requirements for manufacturing portable ladders. The Ontario Ministry of Labour has established standards for job-built wooden ladders, while the International Standards Organization has issued Standard ISO-2860 relating to “Access Ladders on Earth Moving Machinery”.

The most common materials for ladders are aluminum, wood, steel, and fiberglass-reinforced plastic.

Wooden ladders deteriorate more rapidly than those made of more durable materials. They must never be painted because paint hides signs of deterioration and may accelerate rotting by trapping moisture in the wood. However, they may be treated with a clear non-toxic wood

preservative or coated with a clear varnish. Inspect wooden ladders frequently for splits, shakes, or cracks in side rails and rungs; warping or loosening of rungs; loosening of attached metal hardware; and deformation of metal parts.

Although aluminum ladders are popular and more widely used than wooden ladders in construction, they are also more susceptible to damage by rough usage. Because they conduct electricity well, aluminum ladders must not be used where electrical contact is possible. Check side rails and rungs regularly for dents, bends, and loose rungs. If dented, the ladder should be taken out of service until repaired by a competent person. If repair is not possible, the ladder should be destroyed.

Fiberglass-reinforced plastic side rails are becoming more common and are generally used with aluminum rungs. They do not conduct electricity well and are resistant to corrosion. They are lightweight and available in various colours. They are, however, costly and heat-sensitive. They must not be exposed to temperatures above 93.3°C (200°F).

Fiberglass ladders should be inspected regularly for cracks and “blooming.” This condition is evidenced by tufts of exposed glass fiber where the mat has worn off. The worn area should be coated with an epoxy material compatible with the fiberglass.

Because of their weight, steel ladders are generally not used as portable ladders in the construction industry. They are, however, often fixed to permanent structures or mobile machinery.

TYPES

The many types of ladders used on construction sites range from metal ladders permanently mounted on equipment to job-built wooden ladders.

Portable Ladders (Figure 1)

All portable ladders must have non-slip feet or be set up so that the feet will not slip.

Portable ladders are available in various grades: light duty or grade 3; medium duty or grade 2; heavy duty or grade 1. The ladders may or may not be certified to CSA Standard Z11. For construction purposes, it is strongly recommended that only ladders bearing the CSA certification label be purchased and used. They may be slightly more expensive but CSA certification assures that the ladder has been manufactured to a high standard set by experts in ladder construction and use.

The type purchased should be compatible with the degree of rough usage expected. For general construction applications, heavy duty portable ladders are recommended. For certain types of finishing work, however, this degree of ruggedness may not be necessary and medium duty ladders will provide acceptable service. Where medium duty ladders are used, they should be restricted to the application for which they were manufactured and not “borrowed” for rougher service.

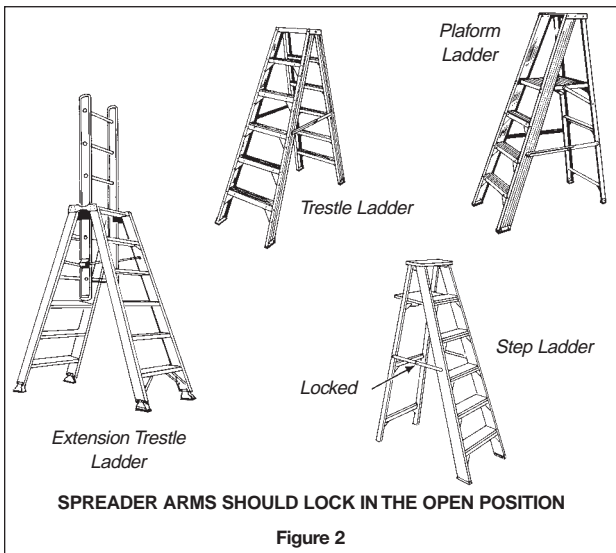
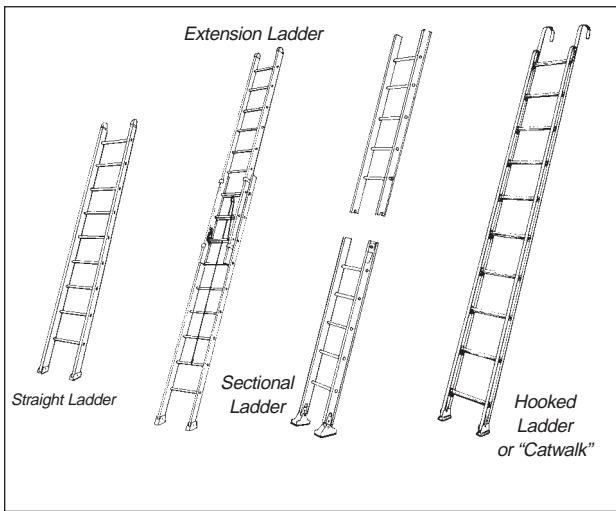

Figure 2

Step, Trestle and Platform Ladders (Figure 2)

Apart from the standards of sound construction and reliable service that should apply to all ladders used on site, the primary consideration with these ladders is that they have strong spreader arms which lock securely in the open position.

Fixed Ladders (Figure 3)

Steel ladders permanently fixed to structures such as stacks and silos are designed for service after construction is complete but are often used by work crews during construction. If the ladders are vertical and there is a risk of falling more than 3 metres (10 feet), a body harness and lifeline, or body harness and channel lock device, should be used by workers climbing up and down or working from the ladders. These ladders must have safety cages starting no more than 2.2 metres (7 feet) from the bottom of the ladder and extending at least 0.9 metres (3 feet) above the top landing. Rest platforms with ladder offsets are required at intervals no more than 9 metres (30 feet) apart where a fall-arrest system is not used. Vertical ladders permanently fixed to structures should comply with Ontario Ministry of Labour Engineering Data Sheet 2-04.

Special Purpose Ladders (Figure 4)

These ladders should be used in accordance with manufacturers' directions and only for the special applications intended.

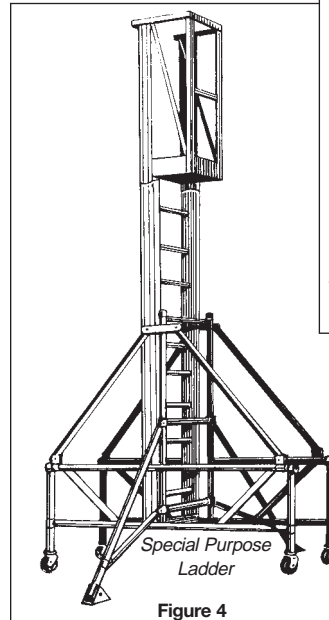

Figure 4

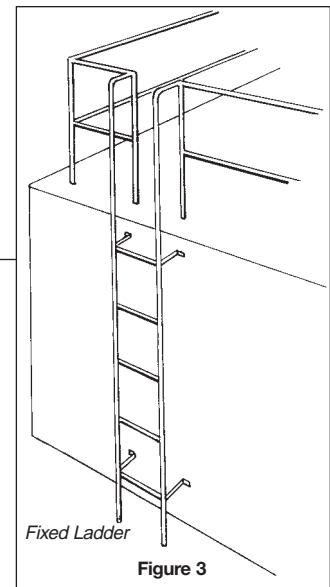

Figure 3

Job-Built Wooden Ladders (Figure 5)

Job-built ladders should be constructed according to good structural carpentry practice.

The wood should be straight-grained and

free of loose knots, sharp edges, splinters, and shakes. Rungs should be clear, straight-grained, and free of knots.

Job-built ladders must be placed on a firm footing and be securely fastened in position.

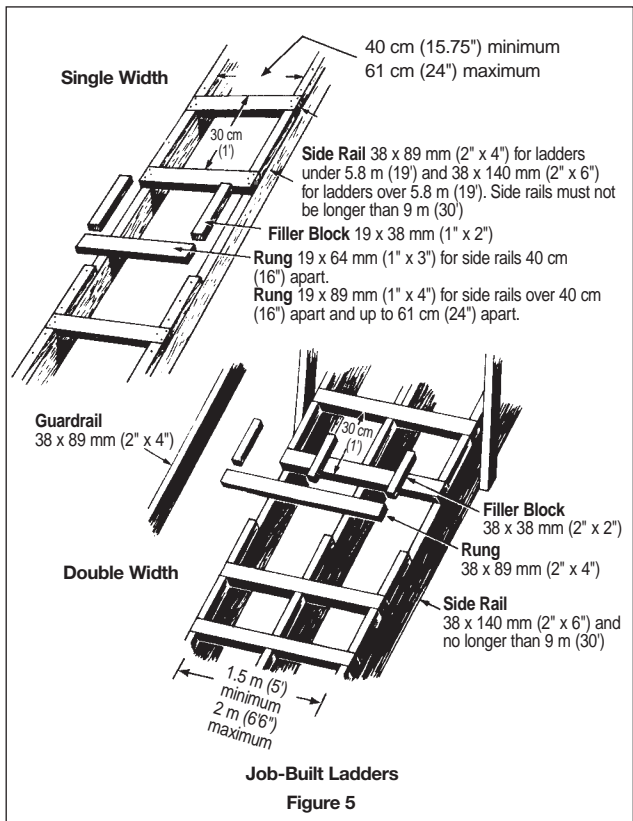

Job-Built Ladders
Figure 5

Remember — a wooden ladder should not be painted or coated with an opaque material.

A straight wooden ladder should not be longer than 9 metres (30 feet).

Job-built ladders are heavy and not recommended where portability is important. Because they are made of wood and often used by a whole crew of workers, job-built ladders deteriorate rapidly. They should be inspected every day or so. If defective, they must be repaired immediately or taken out of service and **destroyed**.

SUPERVISION AND USE

The Supervisor's Task

Ladder injuries can be significantly reduced by control of usage and improved site management. This requires that supervisory personnel

- train workers to maintain and use ladders properly
- evaluate the access requirements of a specific work assignment
- choose the best means of access for the job.

Portable ladders should be used only where safer means of access such as stairs, scaffolds, manlifts, or ramps are not suitable or practical. Supervisors must consider the number of workers requiring access to elevated work locations as well as the extent and duration of the work before deciding on the safest and most economical means of access.

Ladders should not be used by large crews of workers. Basic considerations of efficiency usually indicate that other types of access such as stairs or even personnel hoists are much more suitable where significant numbers of workers are making repeated use of the access.

Where a significant amount of elevated work is to be performed by even one tradesman in an area, ladders are not recommended. Other types of access such as stationary or rolling scaffolds or powered elevating platforms will usually be more efficient and significantly reduce the potential for accidents.

In deciding on the best type of access for various tasks and work locations, management should also consider the amount of material involved; the time workers spend on the access equipment; weather conditions; equipment available on site; condition of surface from which access must be made; room available; potential for shared use with other trades, and so on. It is critical that consideration be given to worker access for specific tasks and for entire work areas. Ladders must not be used where other means of access are practical and safer.

If there is no practical alternative to ladders, supervisors should ensure that ladders are suitable and in good condition and personnel are trained to use them properly. Ladder stabilizers on straight and extension ladders are strongly recommended where ladders are the only means of access.

In addition to proper training, planning, and organizing for worker access, supervisory personnel must exercise control of all access situations. The supervisor must check that planning and directions are being carried out by workers. Although very important, the control function is often given insufficient attention by the busy supervisor. With ladders, as with other supervisory responsibilities, details overlooked today can become problems tomorrow.

Proper Use of Ladders

More than 80 percent of ladder accidents are related to improper use or application of the equipment. Supervisors must control the application of equipment to particular situations. But personnel using the equipment must also be trained to use it. Training should include the following precautions.

- Check the ladder for defects at the start of a shift, after it has been used in another location by other workers, or after it has been left in one location for a lengthy period of time. (See the end of this chapter for inspection procedures.)
- Areas surrounding the base and top of the ladder should be clear of trash, materials and other obstructions since getting on and off the ladder is relatively more hazardous than other aspects of use.
- The base of the ladder should be secured against accidental movement. Use a ladder equipped with non-slip feet appropriate for the situation, nail a cleat to the floor, or otherwise anchor the feet or bottom of the side rails (Figure 6).
- The ladder must be set up on a firm level surface. If its base is to rest on soft, uncompacted or rough soil,

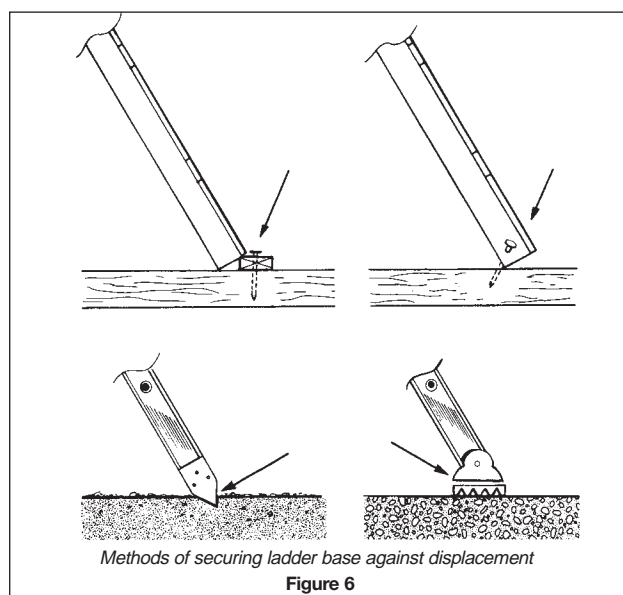

a mud sill should be used (Figure 7).

- The top of the ladder should be tied off or otherwise secured to prevent any movement (Figure 8). If this is not possible, given the type of ladder or circumstances of its use, one worker should hold the base of the ladder while it is being used.
- If a ladder is used for access from one work level to another, the side rails should extend a minimum of 900 millimetres (3 feet) above the landing. Grab rails should be installed at the upper landing so that a worker getting on and off the ladder has secure handholds.
- All straight or extension ladders should be erected at an angle such that the horizontal distance between the top support and the base is not less than one-quarter or greater than one-third the vertical distance between these points (Figure 9).

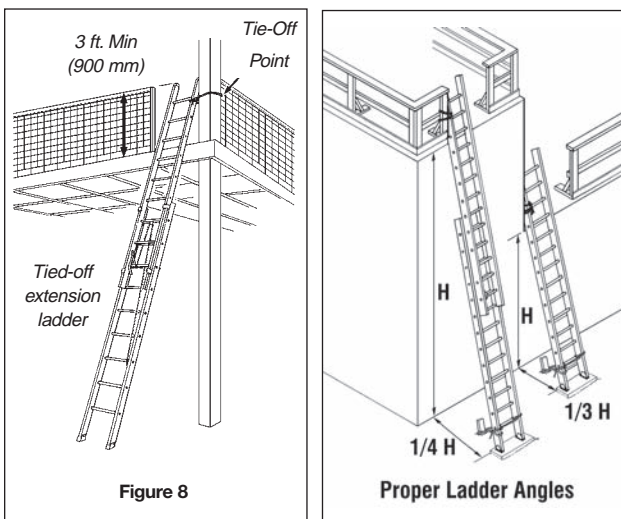
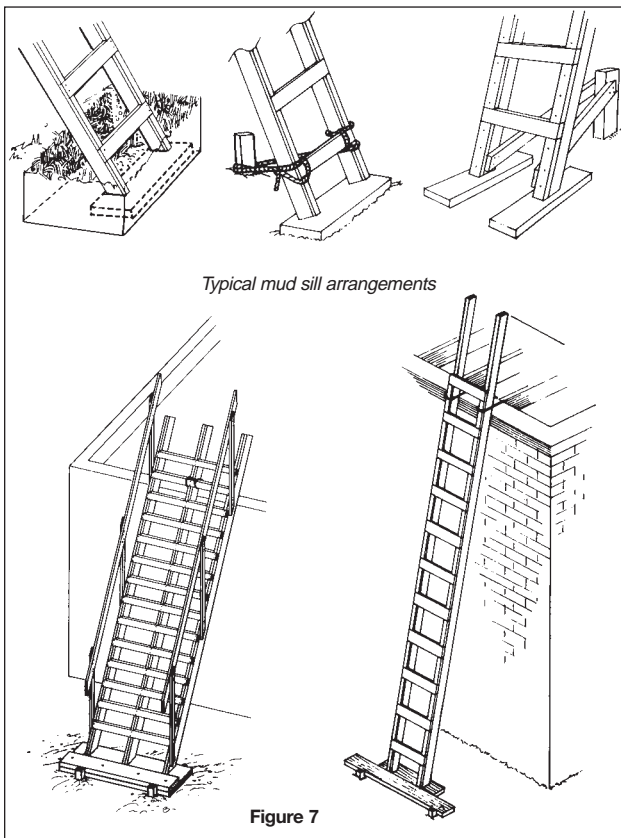

- Before setting up straight or extension ladders, check the area for overhead power lines. Ladders made of aluminum or other conductive material should never be used near power lines. Only competent electricians and linemen using ladders made of non-conductive material are allowed to work in close proximity to energized electrical lines.
- Portable ladders should never be used horizontally as substitutes for scaffold planks, runways, or any other service for which they have not been designed.
- When a task can only be done while standing on a portable ladder, the length of the ladder must be such that the worker stands on a rung no higher than the fourth from the top. The ladder should also be tied off or equipped with a suitable stabilizer.

- Short ladders must never be spliced together to make a longer ladder. Side rails will not be strong enough to support the extra loads.
- Straight ladders should not be used as bracing, skids, storage racks, or guys. They were not designed for these purposes and the damage caused by such abuse can later result in an accident during normal use.
- Unless suitable barricades have been erected, ladders should not be set up in passageways, doorways, driveways, or other locations where they can be struck or displaced by persons or vehicles using the access route.
- Only one person at a time should be allowed on a single-width ladder. In the case of a double-width ladder, no more than two people should be allowed on it at one time and each should be on a separate side.
- Ladders should not be placed against flexible or movable surfaces.
- Always face the ladder when climbing up or down and when working from it.
- Maintain 3-point contact when climbing up or down a ladder. That means two hands and one foot or two feet and one hand on the ladder at all times. This is especially important when you get on or off a ladder at heights (Figure 10).

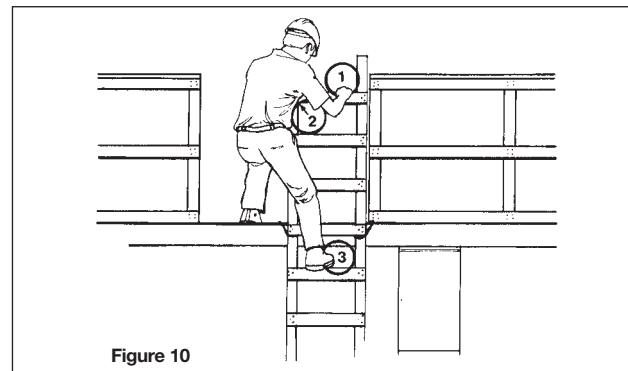

- When working from a ladder, keep your centre of gravity between the side rails. A person's centre of gravity is approximately in the centre of the body at belt height. The location of your centre of gravity can shift when you reach out to either side of a ladder, especially with materials, tools, or equipment in your hands. As the centre of gravity of your body and hand-held objects moves beyond the side rails, the ladder is tending toward instability.
- Whenever possible, avoid climbing up or down a ladder while carrying anything in your hands. Tools, equipment and materials should be placed in a container and raised or lowered by rope, if necessary.
- Workers should be instructed and frequently reminded to keep their boots free of mud, snow, grease, or other slippery materials if they are using ladders.
- Always hold onto the ladder with at least one hand. If this is not possible because of the task to be done and in particular if the work is 3 metres (10 feet) or more above the floor, the worker must wear a safety harness and tie the lanyard off to the structure or to a lifeline before beginning work.
- Never straddle the space between a ladder and another object (Figure 11).

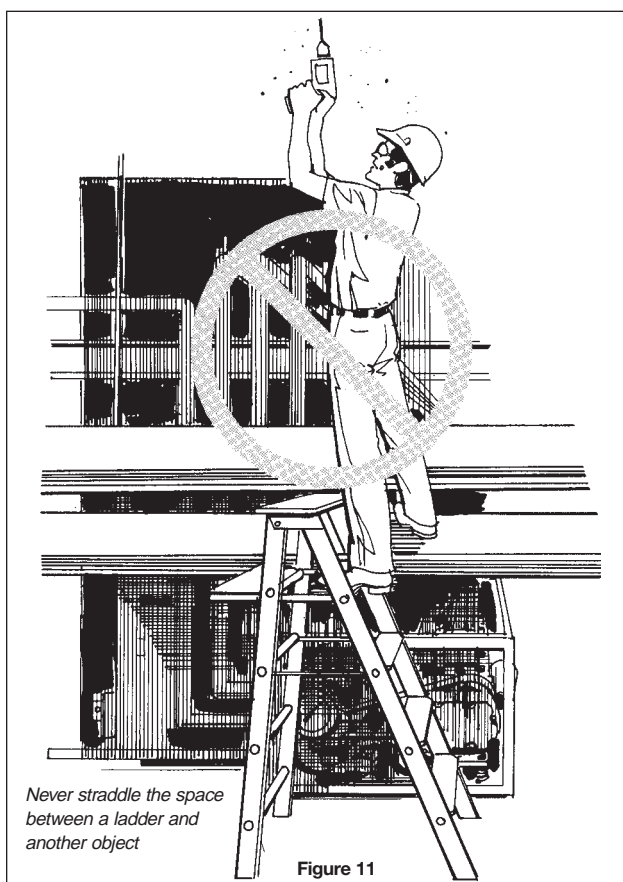

- Persons frequently required to use or work from ladders should wear protective footwear with soles and heels made of slip-resistant materials such as soft urethane.
- Never erect ladders on boxes, carts, tables, or other unstable surfaces.
- Fall-arresting equipment such as ladder climbing devices or lifelines should be used when working from long fixed ladders or when climbing vertical fixed ladders.
- Never rest a ladder on any of its rungs. Ladders must rest on their side rails.
- When erecting long, awkward, or heavy ladders, two or more persons should share the task to avoid injury from over-exertion.
- Instruct all personnel to watch for overhead power lines before attempting to erect any ladder. When overhead power lines are in proximity of the work, aluminum ladders must not be used.

INSPECTION AND MAINTENANCE

Regular inspection and maintenance will increase the useful life of ladders and reduce the number of accidents. A suggested checklist for inspection has been provided at the end of this chapter. Repairs should only be carried out by someone competent and familiar with this kind of work.

Ladders found to be defective should be taken out of service and either tagged for repair or scrapped. Once tagged, the ladder must not be used until repaired. Ideally, the tag should only be removed by the person who took the ladder out of service initially. The tag should be printed in big bold letters with the words "DANGER – DO NOT USE".

General Procedures

Ladders should be inspected for structural rigidity. All joints between fixed parts should be tight and secure. Hardware and fittings should be securely attached and free of damage, excessive wear, and corrosion. Movable parts should operate freely without binding or excessive play. This is especially important for gravity-action ladder locks on extension ladders.

Non-skid feet should be checked for wear, imbedded material, and proper pivot action on swivel feet.

Deteriorated, frayed or worn ropes on extension ladders should be replaced with a size and type equal to the manufacturer's original rope.

Aluminum ladders should be checked for dents and bends in side rails, steps, and rungs. Repairs should be made only by the manufacturer or someone skilled in good aluminum or metal work practices. Replacing a rung with a piece of conduit or pipe is not good practice and should not be permitted.

Wooden ladders are susceptible to cracking, splitting, and rot and should be either unpainted or covered with a transparent finish in order that checks, cracks, splits, rot, or compression failures can be readily detected. Repairs should be consistent with good woodworking practice. Only wood equal to or better than the wood used by the manufacturer should be used in the repair.

The bases, rungs, and steps of all ladders should be examined for grease, oil, caulking, imbedded stone and metal, or other materials that could make them slippery or otherwise unsafe.

Methods of storage and transportation are important. Storage areas should permit easy access and be cool and dry, particularly if wooden ladders are kept there. Areas where the moving of other materials can damage ladders should be avoided. Ladders should be supported during storage and transportation to prevent sagging or chafing. When being transported, ladders should be "top freight" — nothing should be piled on them. If damage does occur, the condition causing the damage should be corrected as well as having the ladder repaired.

Special Considerations

All trades have frequent ladder accidents. To improve accident prevention, supervisors should devote more time to training and reinforcement of training on the job.

Approximately 50 percent of all ladder accidents occur while tasks are being performed from the ladder. Many of these accidents could be prevented by using other types of access equipment such as scaffolds or powered elevating platforms.

Between 30 and 40 percent of all ladder accidents involve unexplained loss of footing. Because inattention may be a cause, training should be strengthened to maintain awareness of the hazards involved in working from ladders.

Many ladder accidents are related to unfavourable weather conditions such as wind, mud, ice, snow, and rain which create slippery and unstable situations. This is an especially important consideration for the outside trades

such as labourers, bricklayers, sheet metal applicators, roofers, and carpenters.

A surprising number of accidents occur when workers take the first step onto the bottom rung of a ladder. While falls from this distance are usually not as serious as those from greater heights, they nevertheless create injuries such as sprains, strains, fractures, and contusions that often result in lost-time claims. Workers should be advised to be careful when stepping onto any ladder. It is often at this point that the unstable, insecure ladder will slide or tip and that muddy or snow-covered boots will slip on the first or second rung. Make sure that boots are clean, that ladders are secure and stable, and that workers are aware of the hazards. Again, this involves supervisor training and continuous reinforcement.

Finally, a large number of accidents occur because workers use straight ladders that are not secured. Site supervisors must rigidly ensure that ladders are either firmly secured (Figures 6-8) or held in place by a second worker.

LADDER USE CHECKLIST

DO

- Familiarize personnel with your ladder safety policy.
- Use a ladder properly suited to the task.
- Construct job-built ladders properly.
- Inspect ladders before use.
- Erect ladders with the proper slope (between 4:1 and 3:1).
- Avoid placing ladders in areas with high traffic or activity such as walkways, entrances, and exits.
- Tie ladders off at the top.
- Block or otherwise secure the ladder base or have the ladder held by a second worker when in use.
- When outdoors, place the ladder base on firm footings such as compacted soil or mudsills.
- Extend the ladder 900 mm (3 feet) above the top landing.
- Clear material, debris, and other obstructions from the top and bottom of ladders.

WHEN CLIMBING

- Use a single-width ladder one person at a time only.
- Maintain three-point contact.
- Do not carry anything in your hands.
- Face the ladder.
- Use a fall-arrest system on long ladders.

DO NOT

- use ladders when a safer means of access is available and practical.
- use metal ladders near live electrical equipment or conductors.
- use ladders horizontally or for some other purpose for which they haven't been designed.
- damage ladders during transport and storage.
- support ladders on their rungs.
- erect long or heavy ladders by yourself.

LADDER INSPECTION CHECKLIST

	YES	NO
1. Are any wooden parts splintered?	<input type="checkbox"/>	<input type="checkbox"/>
2. Are there any defects in side rails, rungs, or other similar parts?	<input type="checkbox"/>	<input type="checkbox"/>
3. Are there any missing or broken rungs?	<input type="checkbox"/>	<input type="checkbox"/>
4. Are there any broken, split, or cracked rails repaired with wire, sheet metal, or other makeshift materials?	<input type="checkbox"/>	<input type="checkbox"/>
5. Are there any worn, damaged, or missing feet?	<input type="checkbox"/>	<input type="checkbox"/>
6. Are there any worn, damaged, or unworkable extension ladder locks, pulleys, or other similar fittings?	<input type="checkbox"/>	<input type="checkbox"/>
7. Is the rope on extension ladders worn, broken, or frayed?	<input type="checkbox"/>	<input type="checkbox"/>
8. Has the rope on extension ladders been replaced by material inferior to the ladder manufacturer's original rope?	<input type="checkbox"/>	<input type="checkbox"/>
9. Are the spreader arms on step ladders bent, worn, broken, or otherwise rendered partly or totally ineffective?	<input type="checkbox"/>	<input type="checkbox"/>

If the answer is "YES" to any of the questions on the Inspection Checklist, the ladder should be tagged so that workers will know it is defective and should not be used. It should be taken out of service immediately and placed in a location where it will not be used until repairs are completed. If the ladder is not to be repaired it should be destroyed.